



Endorsed By



RUGBY  
LEAGUE  
COACHING  
MANUALS

Since 1993

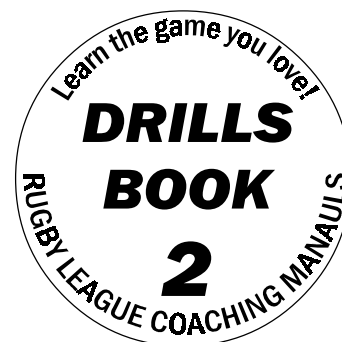

# DRILLS BOOK (2)

## CONTENTS

**66**  
*Drills*

- 2 Touch Games for  
Rugby League Training
- 16 Play The Ball Drills
- 26 Tackling Drills
- 44 Unopposed Passing Drills
- 60 Opposed Passing Drills



VISIT THE  
WEBSITE TODAY!!

## DRILLS BOOK 2

# ***Touch/Tag Games*** ***for Rugby League Training Sessions***

Provided by South Australian Rugby League

---

**T**he emphasis of all these games can be changed by altering certain aspects of the rules. This can be done at both a fitness and a skill level.

Try to alter the rules to achieve what you want to get out of the game. Some may suit you others may need modifications.

For example, if you've been working on the 'play the ball' speed - why not remove the rules about ball carry and correct lines. Place emphasis on what you want to achieve out of the game.

The rules and the field size can be adjusted. Do so to achieve your aims.

### **Notes**

---

---

---

---

---

---

---

---

---

---



## DRILLS BOOK 2

VISIT THE  
WEBSITE TODAY!!

RLCM

Skills

## 2 Minute Elimination

20m x 30m

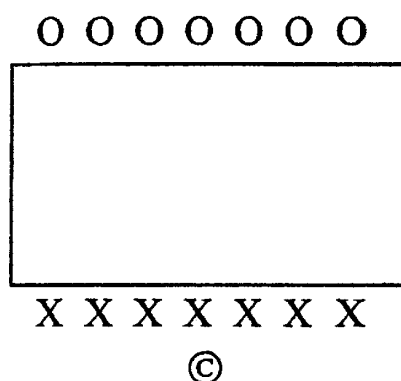

### Overview

Offence starts with the ball and have two minutes to score as many tries as possible. The coach, (C), at regular intervals ( and the same for both teams) takes defensive players out of the game thereby increasing the advantage of the attackers.

### Rules

- Each try scores a point
- For each mistake by the attackers (dropped ball, forward pass, incorrect PTB etc) they lose a point
- The attack can gain a point for any defensive penalty e.g. offside
- Once the try is scored the attack returns to their starting line 20m away and come straight out again
- PTB must be off the ground
- You can eliminate kicking/markers
- Swap roles after two minutes

www.rlcm.com.au



VISIT THE  
WEBSITE TODAY!!

## DRILLS BOOK 2

---

 RLCM

 Skills
 

---

### ***2 v 1 v 1 Challenge***

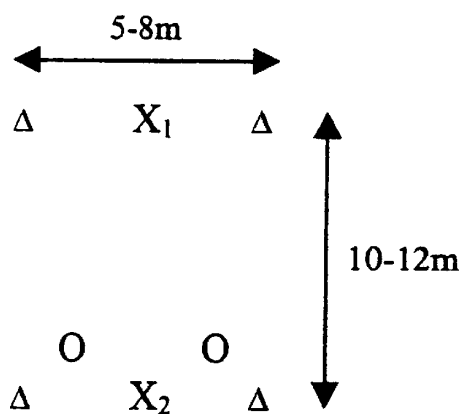

#### ***Overview***

Offence have the ball and try to get past X<sub>1</sub>. As soon as they do, or if they fail, they turn around, and have to get past X<sub>2</sub>. They have 6 goes, back and forward, and see how many successful attempts they make.

#### ***Rules***

- All passes to be backward
- Two handed tags
- Defending players can move forward but must return to their try line after the play

***www.rlcm.com.au***



VISIT THE  
WEBSITE TODAY!!

## DRILLS BOOK 2

---

 RLCM

 Skills
 

---

### 3 Minute Drill

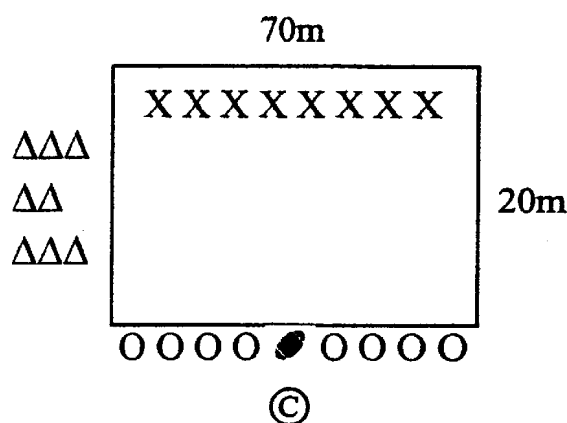

#### Overview

A team has control of the ball for 3 minutes in which they try to score as many tries (points) as they can. One team defends and the other rests. After 3 minutes, teams rotate and the defence becomes the attack and the rest team is on as defence.

#### Rules

- Offence start with a tap in the middle of their line
- They have unlimited tags to score
- If they make a mistake (break rules, forward pass, knock-on etc) they return to the starting line and only when everyone is onside - they start again
- Kicking is allowed
- Tries can be weighted with extra points (e.g. 3 or more pass try - worth 2 points, try scored running correct lines - worth 4 points)
- The coach (C) has spare balls that he places on the centre spot ready for X's to restart so it's continuous
- If the defenders give away 3 penalties that is worth a try to the attackers and they go back to the start again.

www.rlcm.com.au



VISIT THE  
WEBSITE TODAY!!

## DRILLS BOOK 2

---

*RLCM*

*Skills*

---

### ***K-10's***

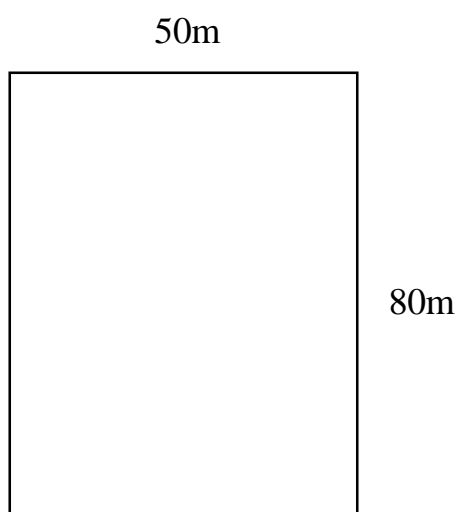

#### ***Overview***

The attacking team plays to a set pattern. Other rules as set by coach.

#### ***Rules***

- A pattern is nominated by the coach
    - e.g Tackle 1 - Go forward
    - Tackle 2 - Go forward off pivot
    - Tackle 3 - Hands
    - Tackle 4 - Go forward
    - Tackle 5 - Play
    - Tackle 6 - Hands/Kick
- and the team must adhere to it.



VISIT THE  
WEBSITE TODAY!!

## DRILLS BOOK 2

RLCM

Skills

### ***Killer Touch***

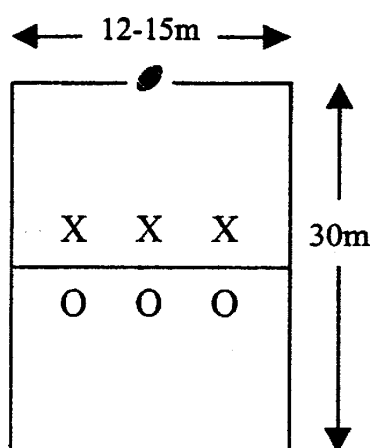

#### ***Overview***

The attacking team has four tags to score.

#### ***Rules***

- Teams face off at half way
- On call, both teams run to their own goal line and turn around
- The attackers pick up the ball and try to score (normal rules)
- On a tag, the defenders have to get back to their line before defending again
- The tagged ball carrier must hit the ground, get up and play the ball before they continue to try and score
- The attackers are allowed four tags to score

#### ***Additional Information***

If the PTB is too quick and the defence isn't getting enough time to recover, you may get the tagged player to roll onto his back or something else that slows him down.



VISIT THE  
WEBSITE TODAY!!

## DRILLS BOOK 2

---

 RLCM

 Skills
 

---

### *Channel Drill*

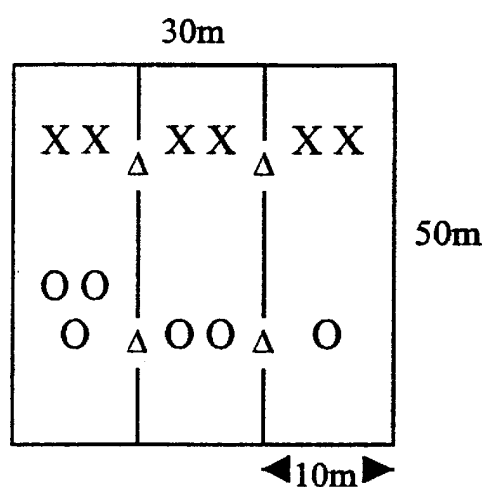

#### *Overview*

Defenders are restricted into certain 'corridors' or channels. The attack can move anywhere as long as they stay outside.

#### *Rules*

- Clearly identify the 'channels' with markers or lines on the field.
- The attackers have 6 tackles to score a try
- No markers in defence
- The defenders are given restricted areas that they are allowed in
- If a defender leaves their channel, the attackers get a new set of 6 tackles

www.rlcm.com.au



VISIT THE  
WEBSITE TODAY!!

## DRILLS BOOK 2

RLCM

Skills

# *Double Layer Defence*

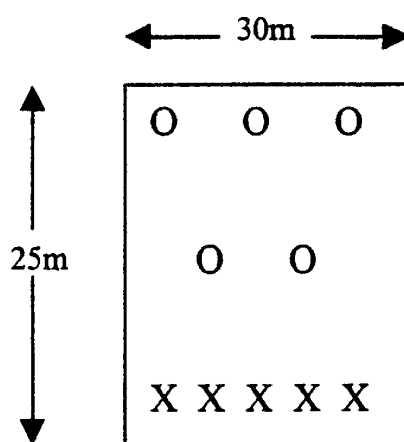

### *Overview*

The attackers have control of the ball for 2 minutes in which they try to score as many points as possible.

### *Rules*

- The attack has 2 minutes in control of the ball
- The object is to score tries at the far end of the grid
- They have 5 players who first try to get past the two defenders in the middle of the grid
- When they get past them, the middle defenders are out and the 3 defenders on the line may now move forward to stop the attack
- After a try is scored or the attackers make a mistake (knock on or forward pass) they return to their starting line and recommence until 2 minutes is up.
- The defenders can stop the attack by tagging them, knocking the ball down or intercepting it.

www.rlcm.com.au



VISIT THE  
WEBSITE TODAY!!

## DRILLS BOOK 2

---

*RLCM*

---

*Skills*

### ***2 Pass Forcing Back***

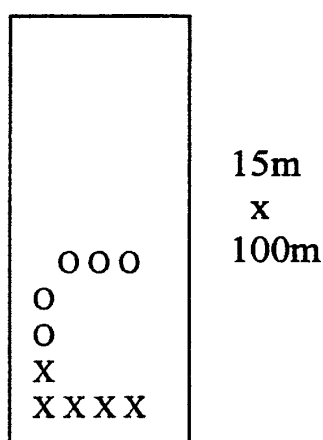

#### ***Overview***

The idea is not to score tries but to force your opponents back to or over their line. When that happens, your team gets a point. The object of the game is to develop go forward play.

#### ***Rules***

- The ball starts with X's on a line 25 metres out from their line
- The team with the ball gets a point if they can force the defenders back over their try line within their six tackles
- The game then restarts with the defenders now taking a tap on their 25m line
- If they don't get to the line then the other team takes over possession
- The attacking team is only allowed 2 passes per tackle
- Normal rules apply
- The defence team has to go back 10 metres at each touch apart from the markers if they are in the game
- Ball to be played off the ground

***www.rlcm.com.au***



VISIT THE  
WEBSITE TODAY!!

## DRILLS BOOK 2

---

 RLCM

 Skills
 

---

# Match The Defenders

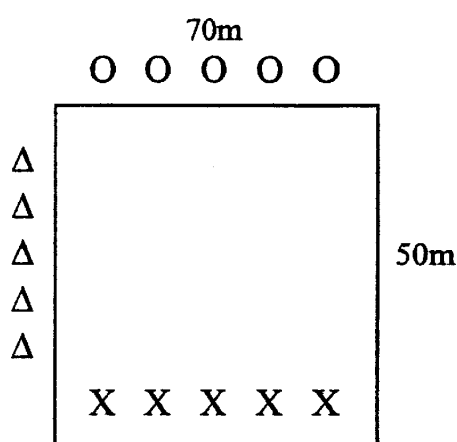

### Overview

The team with the ball has as many tackles to score as there are defenders e.g. 2 defenders, 2 tackles. The coach nominates the number of defenders before giving the ball to the attackers.

### Rules

- The coach nominates the number of defenders (X's) from 1-5
- He then gets a ball to offence and they have the same number of tags to score
- If attack is unsuccessful they get to rest and they resting teams comes on as attack

### Additional Information

Depending on what you're emphasizing, you can vary the rotation. To build pride in defensive effort - successful defending team remains on. To reward good attack and challenge them, the attackers can remain on.



VISIT THE  
WEBSITE TODAY!!

## DRILLS BOOK 2

---

RLCM

Skills

---

# *One Tackle Rugby League*

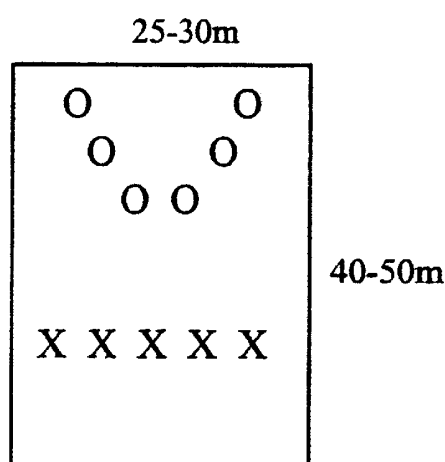

### **Overview**

Teams only get one tackle to score a try.

### **Rules**

- Defensive line back 5-10 metres depending on fitness and skill level.
- If the defenders intercept or pick up a loose ball, play on and their first touch is a zero tag, they get one more go.
- The tackled player should play the ball standing up
- No markers in this game

### **Variation**

You may wish to make this two or three tackles instead of one.

www.rlcm.com.au



## DRILLS BOOK 2

VISIT THE  
WEBSITE TODAY!!

RLCM

Skills

## Gate Touch

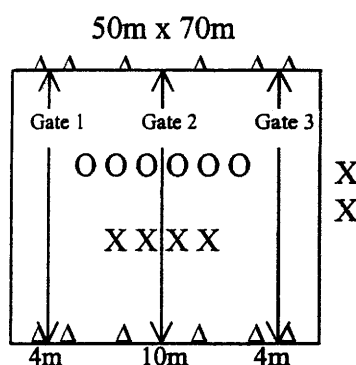

### Overview

The attackers have the ball for 6 tackles during which time they try to score a try. The gates are worth extra points if you cross the try line between them. The defenders have to decide which is the best way to defend e.g. protect the gates, or don't worry about them.

### Rules

- Normal Touch rules
- 2 defenders drop off to the side of the field at all times but come on when your team gets the ball back
- If the ball carrier crosses the try line between Gates 1 or 3 the try is worth 3 points, in between Gate 2 the try is worth 8 points. Anywhere else is worth 1 point
- Defenders can't 'camp' in front of the gate to stop the attackers coming through

### Additional Information

By varying the worth of the gate, in terms of points, you can vary the emphasis. In the above example it is most likely that the defenders will concentrate on covering the middle encouraging shifting of the ball to the edges.



## DRILLS BOOK 2

VISIT THE  
WEBSITE TODAY!!

RLCM

Skills

## 3 v 2 Touch

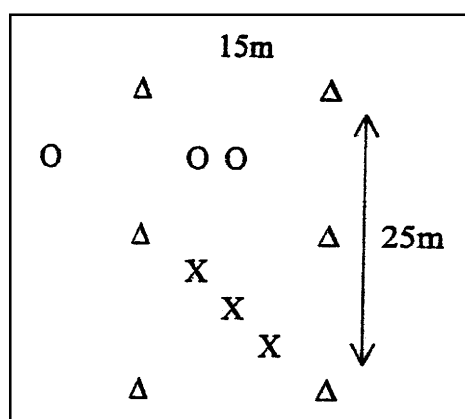

### Overview

The defensive team drops a player off to the side so the attackers always have an advantage.

### Rules

- The attack has 6 tackles to score
- After a tag is effected the ball carrier stops, taps the ball against his foot and has the option of running again or passing
- A change over is ruled for forward passes and knock ons
- The defensive players retreat 3-5 metres as set by referee which is on the sideline moving up and down.

When the attack loses control of the ball or scores a try they now become the defence, a player immediately drops off to the sideline and the other other teams' player returns to the field.

### Variation

This same concept could become 2 v 1, 4 v 3, 5 v 3, 6 v 4 etc. and you could also alter the number of players who drop off.

www.rlcm.com.au





VISIT THE WEBSITE TODAY!!

## DRILLS BOOK 2

# PLAY - THE - BALL DRILLS

*The emphasis of drills can be changed by altering certain aspects of the drill, such as field size and number of players to achieve your aims.*

## Secure & Play

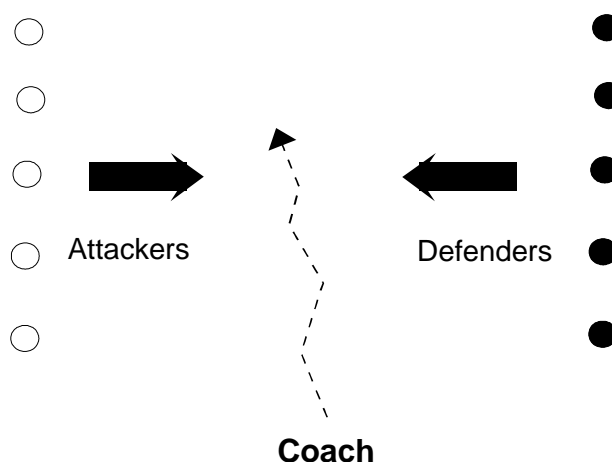

### Setting

2 groups of 5 players  
Grid approx 20 m X 20 m

- Coach rolls ball into the centre of grid and nominates which group is to regather ball and become attackers, with the other group becoming defenders
- Attacking team regather and start their attack by Playing The Ball
- Defending team line up respectively on attacking players with Markers defending the ruck area
- Aim is to have dummy half passing correctly and players to reach advantage line



VISIT THE  
WEBSITE TODAY!!

## DRILLS BOOK 2

# Continuous Play The Ball

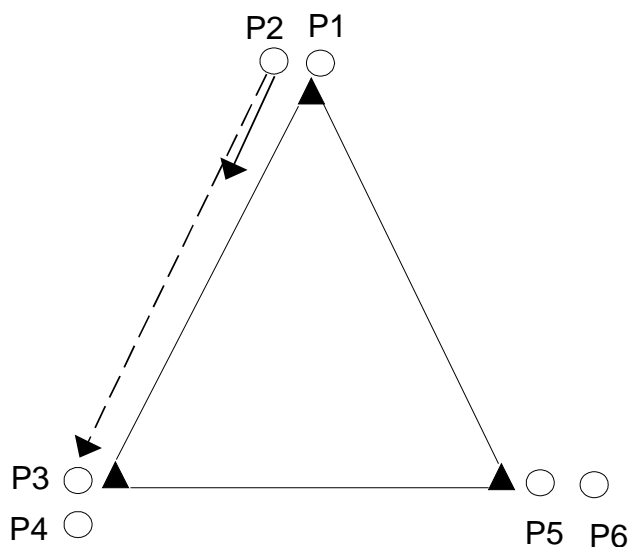

### Setting

6 Players

Triangle begin 5m x 5m, advance to 10m x 10m

- P1 PTB to P2 who passes to P3
- P2 follows ball
- P3 PTB to P4 who passes to P5
- P4 follows ball
- P5 PTB to P6 who passes to P1
- P1 follows ball
- Swap players positions after several rotations

### Variations

Reverse ball movement.

Increase triangle size to include longer and spiral passes.



VISIT THE WEBSITE TODAY!!

# DRILLS BOOK 2

## Play The Ball (1)

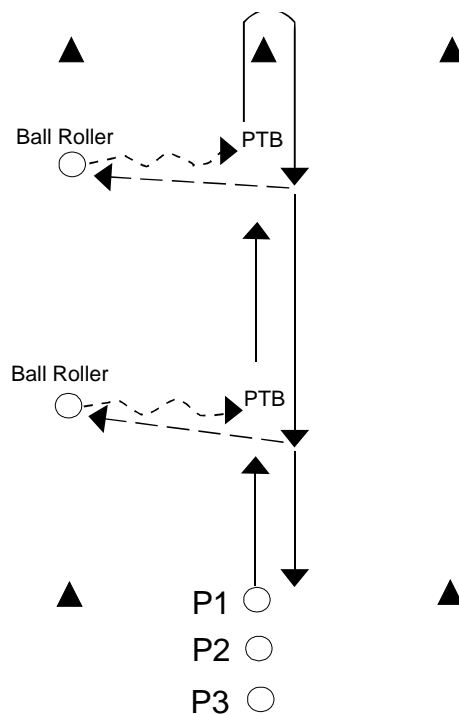

### Setting

5 Players to 1 group - 3 runners, 2 ball rollers

Grid approx 15 m X 10 m

- 2 ball rollers stand 5m apart on the long side of the grid
- The remaining players line up in single file at the end
- The first ball is rolled in front of P1
- P1 regathers ball, goes to ground, regains feet and PTB
- The second ball is then rolled for P1
- P1 regathers, goes the ground, regains feet and PTB
- P1 continues to end of grid, runs around marker and returns
- On return P1 passes the ball from the ground to the ball rollers
- Drill then continues for P2



## DRILLS BOOK 2

VISIT THE  
WEBSITE TODAY!!

### ***Play The Ball (2)***

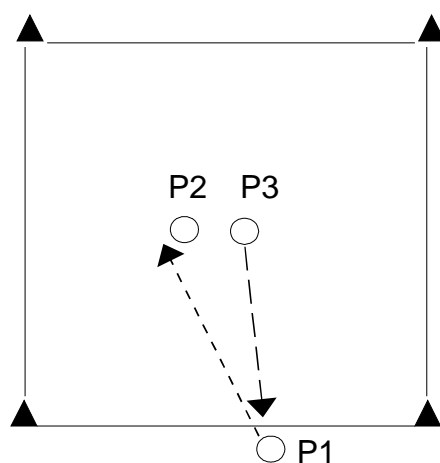

#### **Setting**

3 Players

Grid approx 15 m X 10 m

- P1 is positioned on side of grid
- P1 rolls ball to the centre of grid
- P2 regathers ball, goes to ground, regains feet and PTB to P3
- P3 passes ball to P1
- P1 rolls ball back into grid for drill to continue
- Players swap positions

#### **Variations**

Add Markers to chase dummy half pass.

Add Player opposite P1 (pass of both sides, test markers)



## DRILLS BOOK 2

VISIT THE  
WEBSITE TODAY!!

### ***Play The Ball Grid (1)***

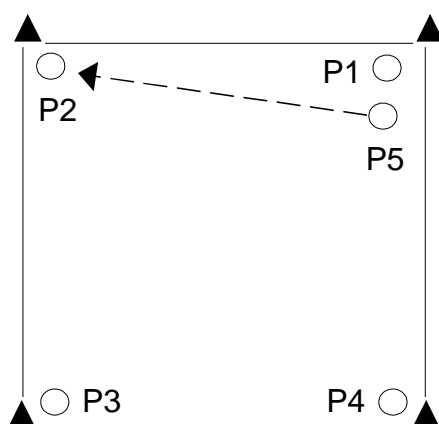

#### **Setting**

5 Players

Grid approx 8 m X 8 m

- 1 Player on each corner plus 1 Dummy Half
- P1 PTB to P5 who passes to P2
- P5 follows pass
- P2 then PTB to P5 who passes to P3
- P3 follows the ball and the drill continues around the grid
- Players swap positions after several rotations

#### **Variations**

Change direction of passing.

Vary size of grid for longer and spiral passes.



VISIT THE WEBSITE TODAY!!

## DRILLS BOOK 2

### ***Play The Ball Grid (2)***

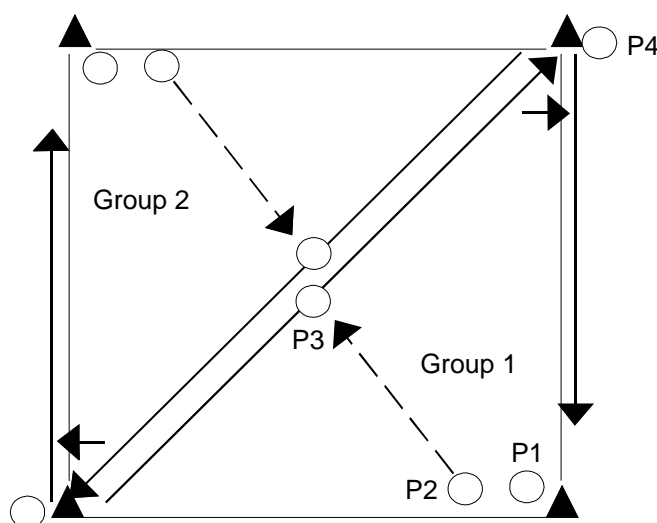

#### **Setting**

8 Players in 2 groups  
Grid approx 10 m X 10 m

- P1 PTB to P2
- P2 passes the ball to P3 who is running diagonally across grid
- As P3 approaches corner he pops a pass to P4
- P4 then runs the ball to the starting corner and PTB to P1 who has now become the Dummy Half
- Once P2 has passed the ball he moves to the adjacent corner to be in position to receive the ball from P1
- Have 2 groups operating in the 1 grid

#### **Variations**

P3 runs in the second groups triangle to create more traffic.



VISIT THE  
WEBSITE TODAY!!

## DRILLS BOOK 2

### **Zig Zag Dummy Half Passing (1)**

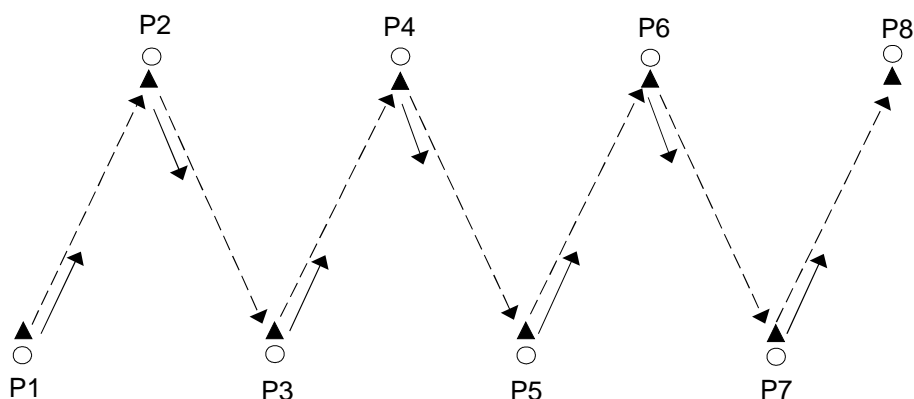

#### **Setting**

1 Passer, 5-6 Receivers

Grid approx 30m x 8m channel

- P1 passes the ball from the ground to P2
- P1 then follows the ball
- P2 PTB for P1 who passes to P3
- P1 follows the ball
- P3 PTB for P1, who passes to P4
- The drill continues with P1 acting as Dummy Half and alternating which side the ball is passed from with each play

RUGBY LEAGUE COACHING MANUALS *Online*  
**www.rlcm.com.au**

www.rlcm.com.au



VISIT THE  
WEBSITE TODAY!!

## DRILLS BOOK 2

### **Zig Zag Dummy Half Passing (2)**

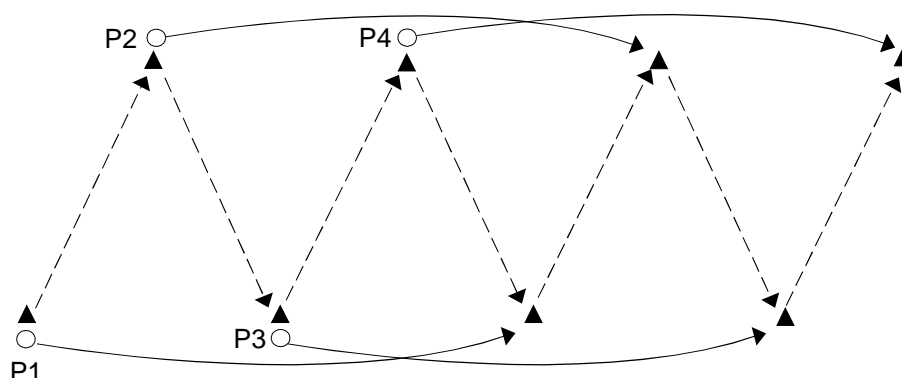

#### **Setting**

4 Players

Channel 8m wide

- P1 passes the ball from the ground to P2
- P2 receives ball, places on ground, releases and then passes to P3
- P3 receives ball, places on ground, releases and then passes to P4
- P4 continues drill down the channel
  
- Once player has passed the ball he moves quickly to the next allocated position on his side of the channel

#### **Variations**

Players run through the middle of channel to the allocated position creating traffic and distractions.

Players run through middle of channel as well as swapping sides.



## DRILLS BOOK 2

VISIT THE  
WEBSITE TODAY!!

# Continuous Marker

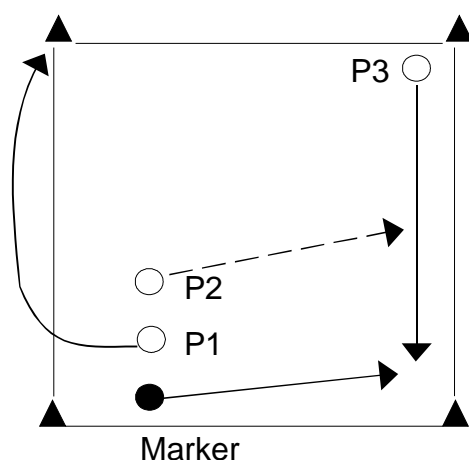

### Setting

4 Players

Grid 8m x 8m

- P1 PTB to P2
- (Once P1 PTB he moves to become the runner to receive the return pass after the next PTB)
- P2 passes to P3
- Marker chases and attempts to tackle player P3
- P3 PTB to P2 who passes back to P1
- Marker once again chases and attempts tackle
- Drill continues back and forth across grid

### Variations

Decrease or increase the size of the grid for skill level or specific passes.

Increase speed of drill for higher intensity.

Create game points for dropped ball, tackle count in time limit, etc



VISIT THE  
WEBSITE TODAY!!

## DRILLS BOOK 2

### 6 Man PTB Routine

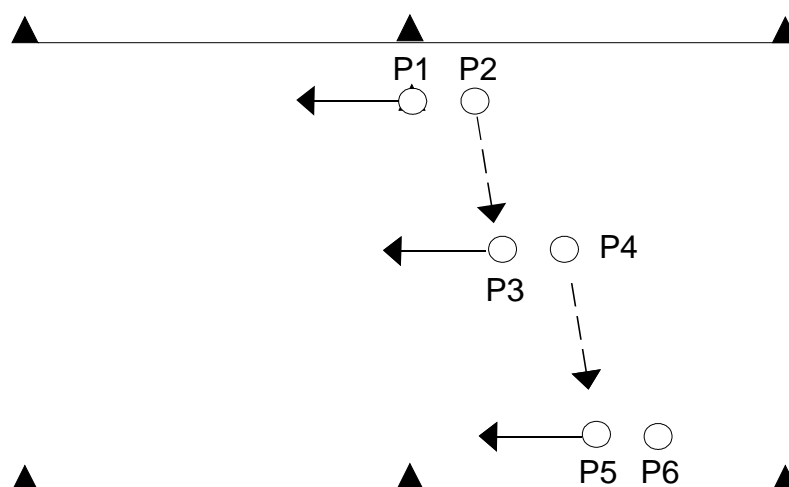

#### Setting

6 Players

20 metre channel, Field Length

- P1 starts movement by running forward then going to ground
- P1 PTB to P2 who passes to P3
- P3 goes to ground, PTB to P4 who passes to P5
- P5 goes to ground, PTB to P6 who passes ball back to P3
- Drill continues back and forth
- Players change roles with next run through.

#### Variations

Add markers and defensive line, moving up and back 10 metres.

Coach varies commands as to which player receives ball.

Use all players for the development and exposure to Dummy Halfs role.



VISIT THE  
WEBSITE TODAY!!

## DRILLS BOOK 2

# Tackling Drills

*RLCM would like to thank Dave Ellis, Digi League and John Dixon, Brisbane Broncos for their assistance in compiling these tackling drills.*

*The emphasis of drills can be changed by altering certain aspects of the drill, such as field size and number of players to achieve your aims.*

*RLCM has over 100 drills available including Kicking Drills, Mini & Mod Agility Drills, Play The Ball Drills. For more information visit our website [www.rlcm.com.au](http://www.rlcm.com.au)*

1. Side on Tackle
2. Side on Tackle Grid
3. Tackle Combination
4. Rear Tackle
5. Rear Tackle Grid
6. Rear Tackle / Side Tackle
7. Blocking Tackle
8. Driving Tackle
9. Tackling Technique (1)
10. Tackling Technique (2)
11. Tackle Wheel
12. Tackle Circle
13. 1 on 1 Tackle Drill
14. Tackling Grid
15. Tackle & Adjust
16. Tackle & Retreat

## Notes

---

---

---

---

---



VISIT THE  
WEBSITE TODAY!!

## DRILLS BOOK 2

# Side on Tackle

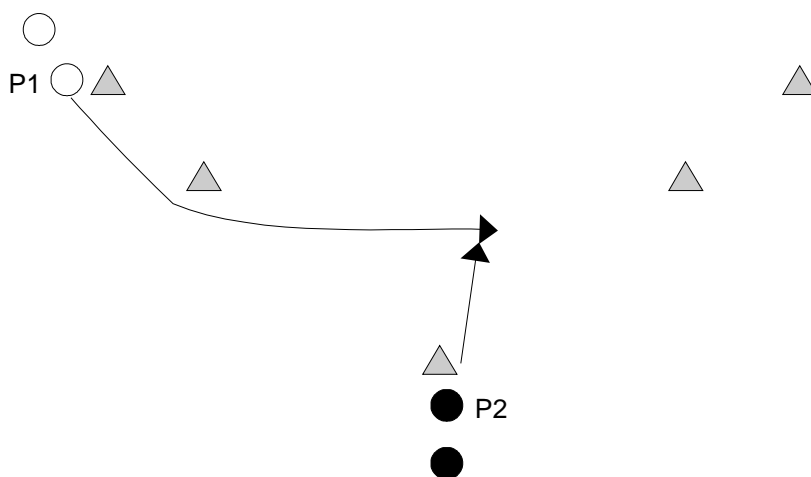

### Setting

2 Players (Min), Grid 10m x 20m

- P1 runs out and follows path around markers
- At midpoint P2 runs out and performs side-on tackle
- P1 continues to other end of grid and prepares for return run
- On return P2 performs side-on tackle using alternate shoulder

### Points

Drill should start at slow pace and progress as technique and confidence improve

Endorsed By 	<b>RUGBY LEAGUE</b> <b>COACHING MANUALS</b>	All Manuals Available Online
<b>www.rlcm.com.au</b>		



VISIT THE  
WEBSITE TODAY!!

## DRILLS BOOK 2

# Side-On Tackle Grid

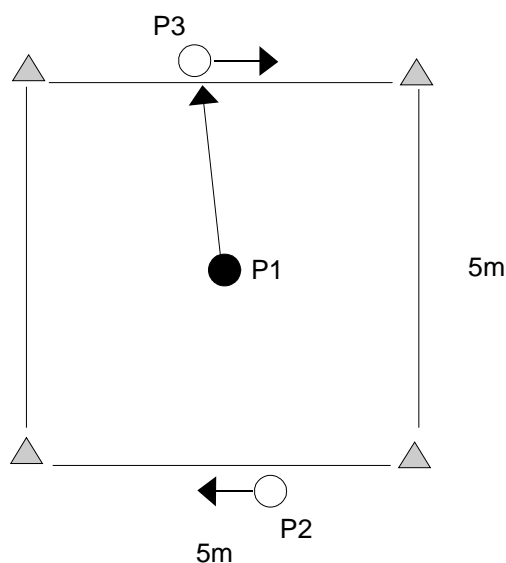

### Setting

3 Players, Grid 5m X 5m

- P1 is the tackler and starts in the middle of the grid
- P2 and P3 start running in the same direction around the grid starting from opposite corners
- P1 picks a player and performs a side-on tackle
- Once tackle is complete P1 must return to the centre of grid and then move to tackle the other player with a side-on tackle

### Points

Drill continues for a set number of tackles and then players rotate

Players being tackled should carry ball in hands

Players use own discretion to change direction and ensure tackler is using both shoulders in tackles



VISIT THE WEBSITE TODAY!!

## DRILLS BOOK 2

# Tackle Combination

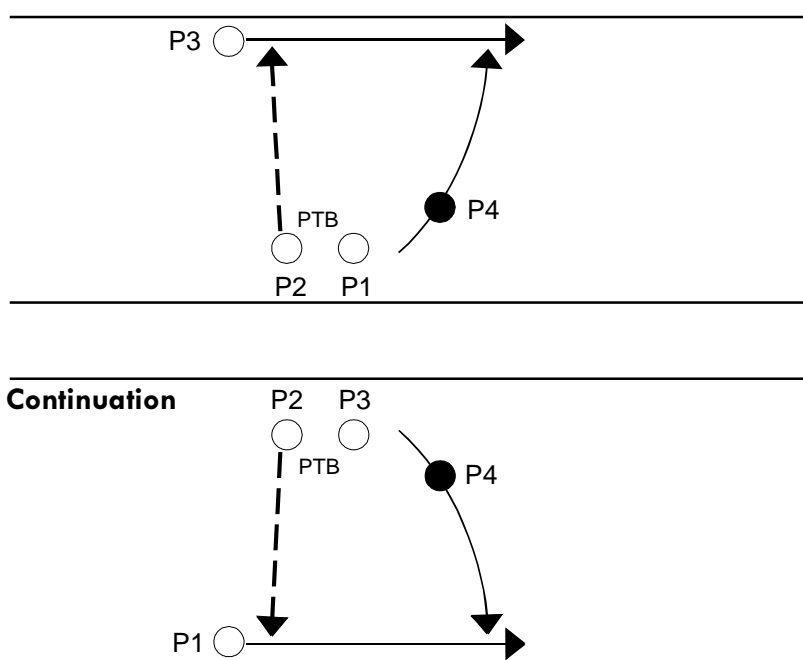

### Setting

4 Players (Min), Grid 8m x 50m

- Players are divided into groups of four
- One player is nominated as the defender and another as the dummy half, the other players are support players
- P1 plays the ball to P2
- P2 as dummy half passes to P3 and then follows
- As the ball is played P4 moves from the marker role to perform a side-on tackle on P3 who is running the ball up
- P3 regains feet and plays the ball to P2
- P2 passes to P1 while P4 once again moves from marker to perform a side-on tackle but this time on P1
- Drill continues downfield



VISIT THE WEBSITE TODAY!!

## DRILLS BOOK 2

# Rear Tackle

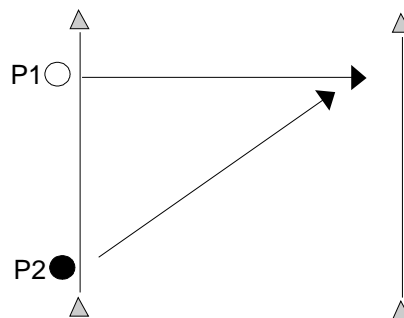

### Progression

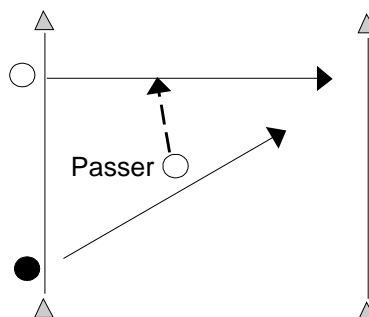

### Setting

2-3 Players (Min), Grid 10m x 20m

- Players divide into 2 groups and line up on two corners of grid
- P1 runs forward heading towards the end of the grid
- P2 leaves after and chases P1 performing a tackle from behind

### Progression

A player is added to the centre of the grid, he passes the ball to either player, the player who does not receive the ball becomes the tackler

### Points

Drill should start as a slow pace and only increase once players become confident and proficient in the tackle



**VISIT THE  
WEBSITE TODAY!!**

## DRILLS BOOK 2

# Rear Tackle Grid

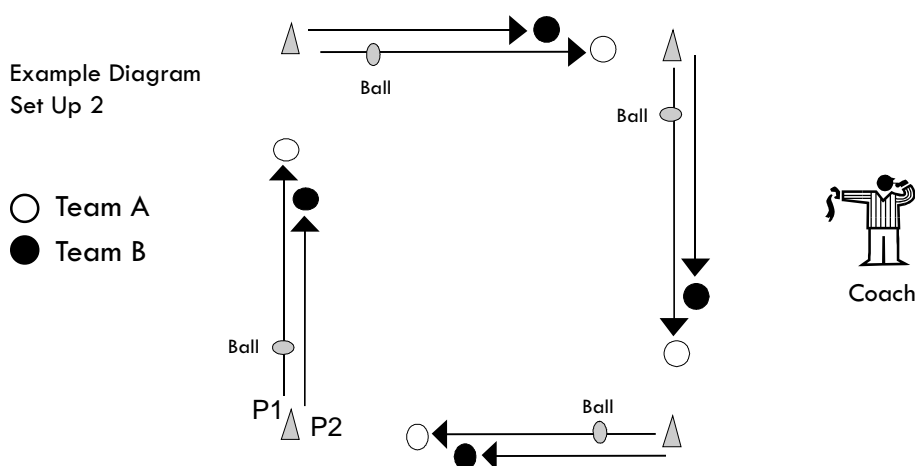

### Setting

8 Players (Min), Grid 15m x 15m

### Set Up 1 (Technique)

- Players pair up with a football on a corner of the grid
- P1 with ball in hands leads out with P2 following
- P2 performs a rear tackle on P1 before he reaches the next corner
- Players continue around grid alternating between tackler and ball carrier

### Set Up 2 (Competitive)

- A ball is placed two metres out from the each corner in the grid
- 8 Players divide into two teams with one player from each team on a corner of the grid
- On command from coach, Team A members run out pick ball and attempt to reach the next corner without being tackled from behind by Team B members, once tackled players move on to the next marker
- Drill continues around grid with coach keeping count of number of tackles made
- Teams swap roles and drill continues



VISIT THE  
WEBSITE TODAY!!

## DRILLS BOOK 2

# Rear Tackle / Side Tackle

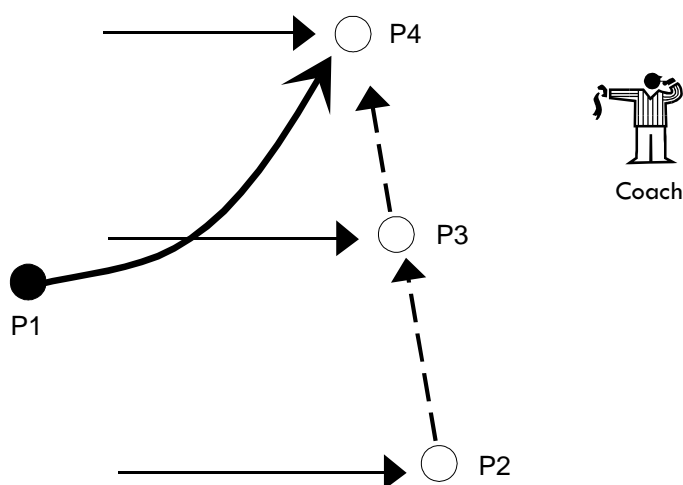

### Setting

4 Players (Min), Grid 10m x 30m

- Players run down the grid passing the ball (P2, P3, P4)
- On coaches command P1 who is trailing performs a rear tackle on the player carrying the ball
- P1 swivels on top of tackled player to a onside marker position
- Players regain their feet
- One of the remaining attacking players moves into the dummy half position and passes the ball to the third remaining player
- P1 then chases and tackles the player to complete the drill

### Progression

Attacking players move to evade tackle



VISIT THE  
WEBSITE TODAY!!

## DRILLS BOOK 2

# Blocking Tackle

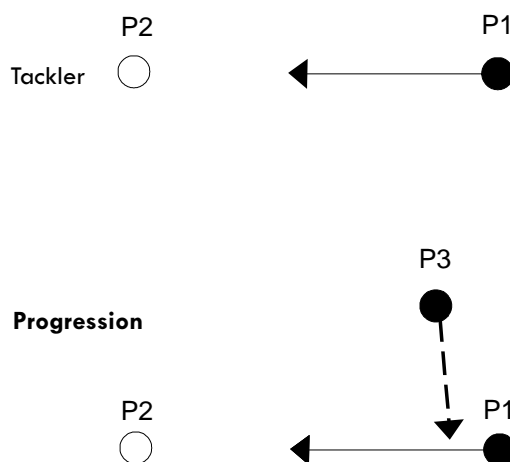

### Setting

3 Players, Grid 10m x 5m

- P1 runs directly at P2 who performs a front on tackle
- Drills continues for a nominated number of tackles alternating shoulders each tackle
- P1 should progressively increase running pace as drill continues

### Points

Tackle should be made around attackers waist allowing for his momentum to bring him to the ground. This tackle should not be a driving tackle

### Progression

- P2 receives a pass from P3 as he approaches the defender



## DRILLS BOOK 2

VISIT THE  
WEBSITE TODAY!!

# Driving Tackle

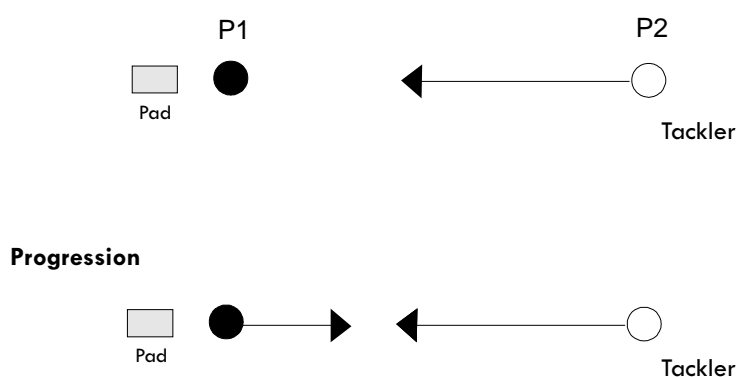

### Setting

2 Players, Grid 10m x 5m, Hit Pad

- P1 (attacker) holds his ground while P2 (defender) moves forward towards him
- P2 performs driving front on tackle on P1 forcing him backwards

### Progression

- P1 moves slowly forward
- P1 moves slowly forward carrying football

### Points

Hit pad should be placed on ground behind P1 for protection  
Emphasis should be placed on technique and not power  
Drill should only be performed at a slow to half pace



VISIT THE  
WEBSITE TODAY!!

## DRILLS BOOK 2

# Tackling Technique (1)

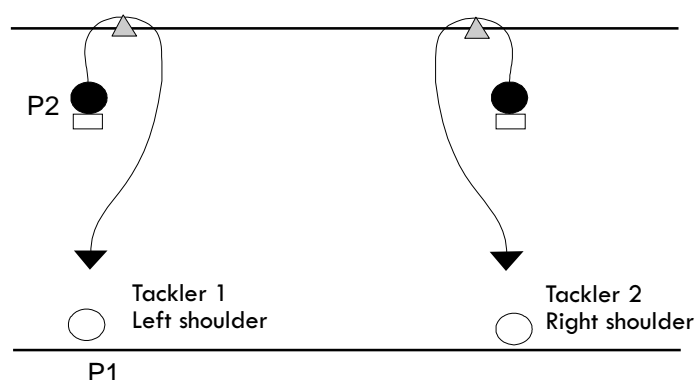

### Setting

2 Players, Tackle Bag, Grid 10m x 5m

- Drill starts with P1 and P2 standing 2m apart (P2 holds hit pad)
- P2 retreats to line and moves forward towards P1
- P1 moves off his line and then makes tackle on P2
- P2 retreats and then moves forward again
- P1 makes tackle using alternate shoulder
- Drill continues for nominated number of tackles alternating shoulders each tackle

### Points

Players head should be forward and on the outside of bag  
Players outside leg should be up close to the bag (left shoulder = right leg)

### Progression

Increase pace and repetition of tackles  
See Tackling Technique (2)



VISIT THE  
WEBSITE TODAY!!

## DRILLS BOOK 2

# Tackling Technique (2)

Continuation from Tackling Technique (1)



Coach signals to players  
to retreat left or right

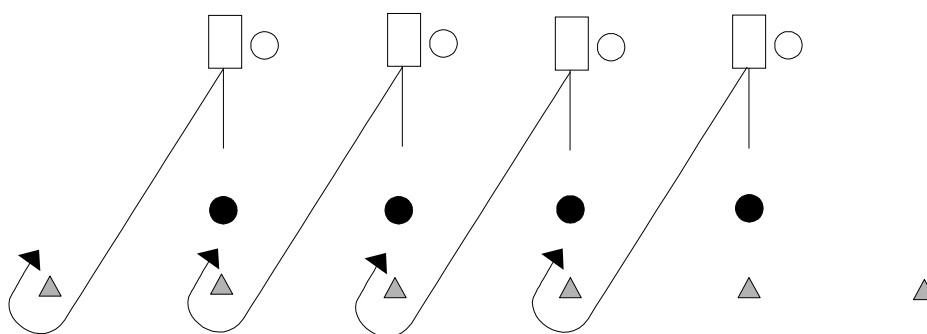

### Setting

4 Players (Min), Tackle Bags, Grid 10m x 5m

- Players Stand opposite tackle bags
- On coaches comand they move forward and tackle bag
- As players regain their feet, they must take notice of signal from coach (pointing left or right), and retreat to the marker which is left or right from where they started, depending on the coach's signal
- On the coach's command players move forward and across and tackle the same bag previously tackled

### Points

Players should always tackle the same bag

Players should communicate and keep defensive line at all times

Players head should be forward and on the outside of bag

Feet should be close to bag and in contact with the gound

www.rlcm.com.au



## DRILLS BOOK 2

VISIT THE  
WEBSITE TODAY!!

# Tackle Wheel

- Defenders
- Attackers

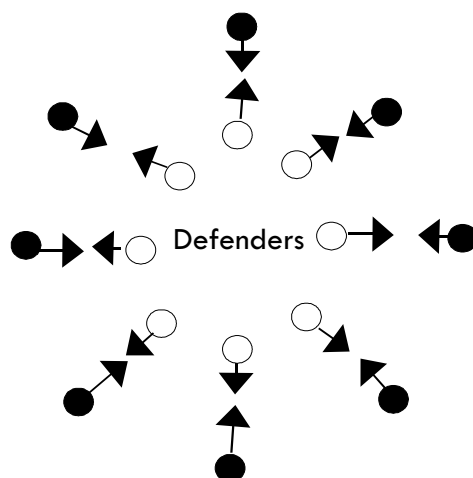

### Setting

6 Players (Min), 20m circle

- Players divide into 2 teams
- Attacking team evenly space themselves around a circle of 20m diameter
- Defending players gather in the middle of the circle facing an opponent
- On coach's command players move towards one another
- Defenders make contact but do not complete tackle
- Emphasis should be more on good technique

### Variation

Coach commands '2 left', '3 right' 'left' etc which means a call of '3 right' would direct defender to the third attacker on their right.



## DRILLS BOOK 2

VISIT THE  
WEBSITE TODAY!!

# Tackling Circle

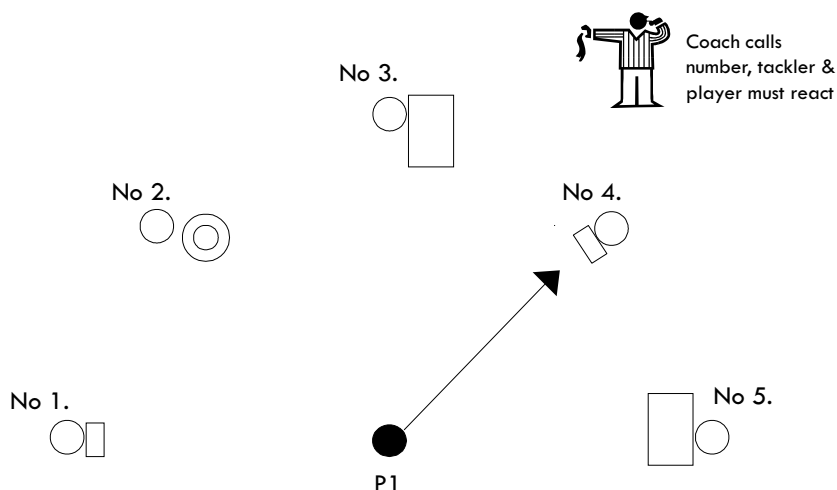

### Setting

6 Players, Tackle Bags, Hit Pads, Tyre Tubes, 10m circle diameter

- P1 is nominated as tackler
- Players holding equipment form circle/semi circle around P1 and are given a number
- Coach calls a number, that player must react, and P1 must either:-
  - Knock down tackle bags
  - Drive Hit Pads backward
  - Bust through inner tubes rolling towards him.

RUGBY LEAGUE COACHING MANUALS *Online*  
**www.rlcm.com.au**

www.rlcm.com.au



VISIT THE  
WEBSITE TODAY!!

## DRILLS BOOK 2

# 1 on 1 Tackle Drill

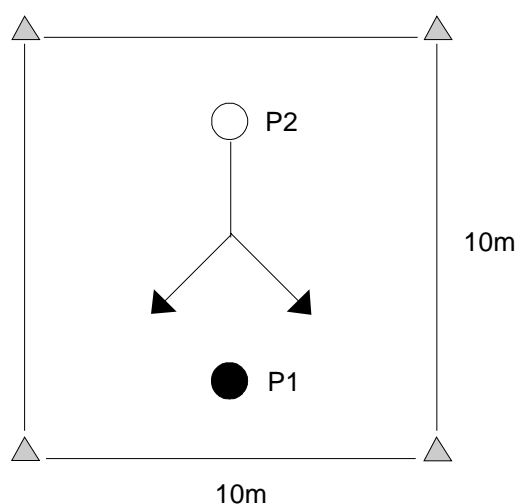

### Setting

2 Players, Grid approx 10m x10m

- P1 and P2 oppose each other inside grid
- P2 is in possession and must attempt to score at other end
- Once P1 secures a two handed grab on P2 the ball is placed on the ground
- P2 retreats two metres and becomes the defender
- P1 picks up the ball and becomes the attacker

### Variation

Progress (1) tackle, (2) Attacker standing in tackle



## DRILLS BOOK 2

VISIT THE  
WEBSITE TODAY!!

# Tackling Grid

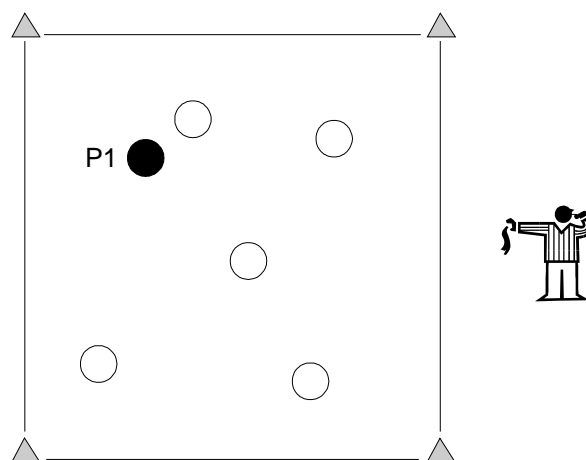

### Setting

6 Players, 5 footballs, Grid approx 10m x10m

- All players are within grid
- P1 is nominated as the defender
- P2 - P4 are attackers, all with football in secure carry
- P1 makes as many tackles as he can in a selected time
- Tackle is completed once player is on ground and held by tackler
- Coach keeps count of number of tackles
- Rotate Players

### Variation

Tackler attempts to keep attacker on his feet and force over the nearest sideline

Progress to 2 tacklers



VISIT THE  
WEBSITE TODAY!!

## DRILLS BOOK 2

# Tackle & Adjust

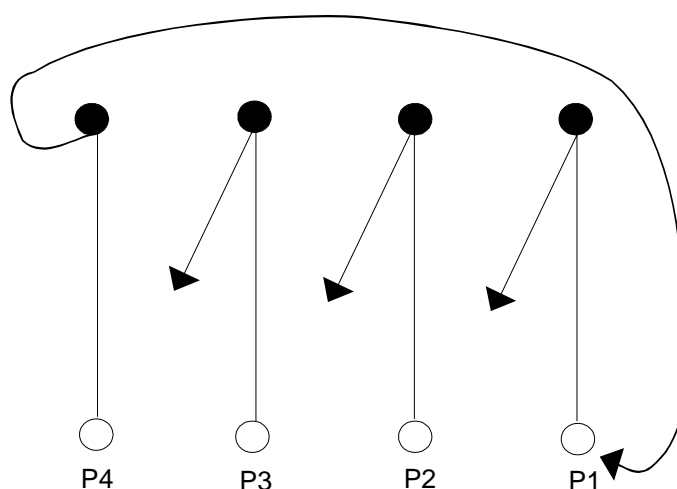

### Setting

8 Players (Min), Grid 12m x 8m, Hit Pad/Tackle Bags

- Players line up in 2 teams, attackers and defenders
- Defenders move up in one line and perform tackle commanded by coach
- Defenders retreat sliding to the marker on their left
- P4 now without a bag in front of him, runs around the back of the bags and rejoins the defensive line at the other end
- P4 yells 'GO' to signal to the other players to move forward and the drill continues

### Points

Defensive line should be maintained at all times

Players should communicate and nominate their target



VISIT THE  
WEBSITE TODAY!!

## DRILLS BOOK 2

# Tackle & Retreat

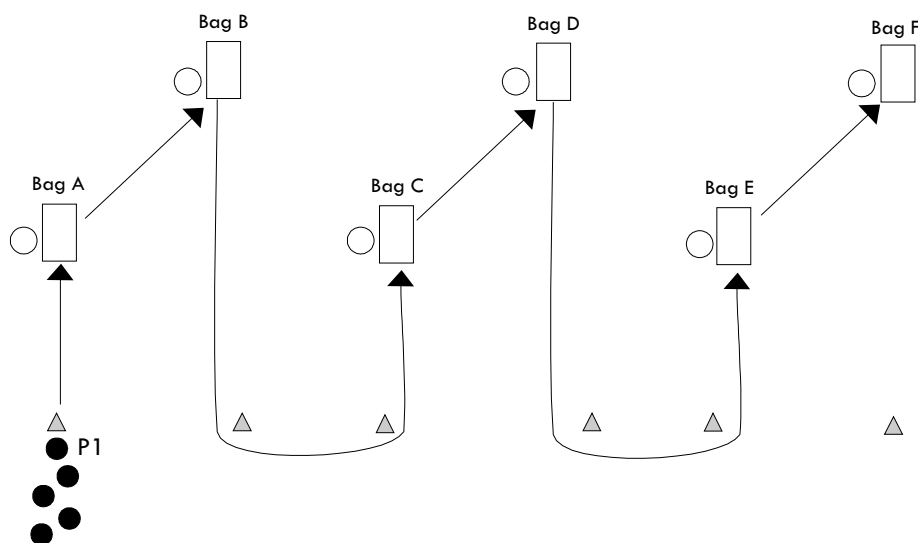

### Setting

All Players, Tackle Bags, Grid 10m in depth

- Players takes position holding tackle bags (1 player per bag)
- Remaining players line up at start position
- P1 moves forward and tackles Bag A, he regains his feet and then tackles Bag B.
- P1 retreats back and around markers and then moves up on Bag C to begin the next set
- The drill continues downfield

### Points

Players head should be forward and on the outside of bag  
Feet should be close to bag and in contact with the ground





VISIT THE  
WEBSITE TODAY!!

## DRILLS BOOK 2

# *Unopposed Passing* **DRILLS**

### *Unopposed Passing Drills to Develop Good Technique for Quick and Soft Hands*

Passing is an essential skill for Rugby League however many players lack good technique. To achieve results good catching and passing techniques should be emphasised at all times as well as communication between players.

Ball control is the major factor in winning and losing games. The skills of catching and passing the football must be taught correctly and reviewed and adjusted at all levels of the game.

The message 'controlling the football wins games' should be paramount with coaches in developing these skills in players.

RLCM would like to thank Dave Ellis, Digi League, John Dixon, Brisbane Broncos, NSWRL Academy and Andrew Hill, Parramatta Eels for their assistance in compiling these drills.

**Visit the RLCM website to order  
Drills Handbooks  
www.rlcm.com.au**

1. Speed Pass Wheel
2. Star Drill
3. Speed Pass Square
4. Passing Circle
5. Quick Hands
6. Traffic Pass (1)
7. Traffic Pass (2)
8. Traffic Pass (3)
9. Pass & Support
10. Keep Away Grid
11. Elimination Tag
12. Football Basketball
13. Line Passing
14. Pairs Passing

www.rlcm.com.au



VISIT THE  
WEBSITE TODAY!!

## DRILLS BOOK 2

# Passing Skills of Rugby League

### STANDING PASS

- Grip - thumbs on top of the ball
- Extend fingers along the ball
- Weight on closest foot to receiver (front foot)
- Swing arms towards target
- Hands continue to point to target after ball is released

### RUNNING PASS (see front cover)

- Grip - as for standing pass
- Weight on leg furthest from receiver ("lean away")
- Turn head and shoulders towards receiver
- Hands extend towards the target
- Aim the ball slightly in front of runner

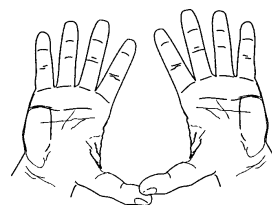

### RECEIVING & CATCHING A PASS

- Relax body to receive
- Hands up in front of chest with body facing towards passer
- Receive ball in hands (gridiron style as in diagram)
- Fingers to form half circle upwards and slightly bent towards passer
- Thumbs touching and resting on top of each other to the bottom
- Back of hands to face the chest
- Watch ball into hands
- Upon catching, grip ball with thumbs and hands, as per standing pass
- Thumbs on top of ball, anticipating quick release to next attacker

### RUNNING IN POSSESSION (see front cover)

- Carry the ball in both hands
- In front of the body, chest height
- Transfer to one arm to allow fend/swerve
- Lean forward for balance

RUGBY LEAGUE COACHING MANUALS *Online*  
**www.rlcm.com.au**

www.rlcm.com.au



## DRILLS BOOK 2

VISIT THE  
WEBSITE TODAY!!

# Speed Pass Wheel

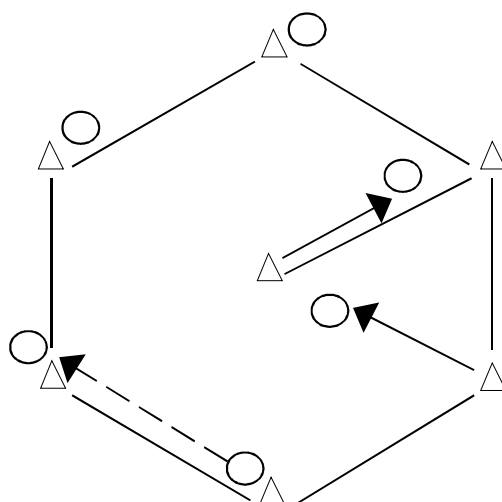

### Setting

6 players, Circle Approx 8m

- Drill starts with 6 markers placed in a circle with a player positioned on each one
- Initially one player starts with the football
- On coaches command ball is passed around the circle in the direction specified, after each player has passed the ball he must run to the centre of the circle, touch the marker and return to his original position
- Progress to two footballs, an even number of players should be used and the drill starts with footballs directly opposite each other

### Points

Add a competition aspect into the drill by counting passes within a selected time



## DRILLS BOOK 2

VISIT THE  
WEBSITE TODAY!!

# Star Drill

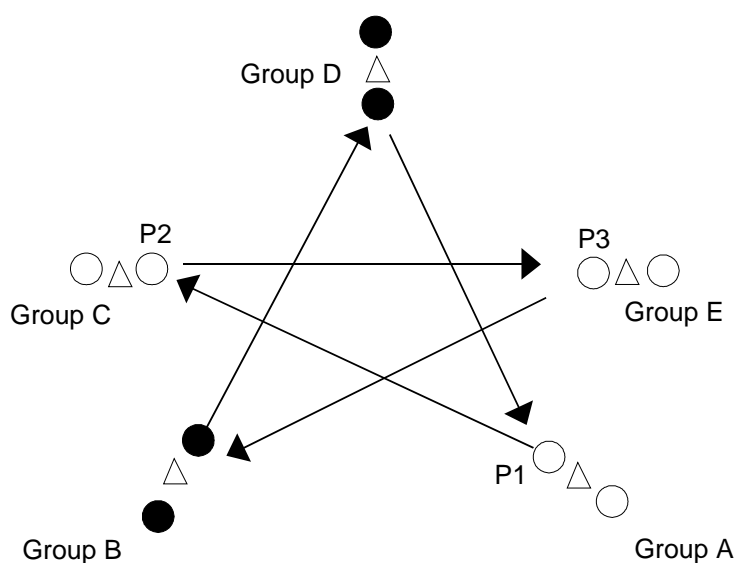

### Setting

10 or more players, 10m star shaped grid

- Divide players into 5 groups and position them at markers in a 5 star shaped grid
- Group A starts with the ball
- P1 runs with the ball towards Group C and pops a pass to the first player (P2) in that group
- P2 then runs towards Group E and pops a pass to the first player in that group (P3) and the drill continues around the star

### Progression

Add a second ball by having Group B start the drill with a ball and running towards Group D.

Eventually add a ball to each group so there are 5 balls being used throughout the drill.



VISIT THE WEBSITE TODAY!!

## DRILLS BOOK 2

# Speed Pass Square

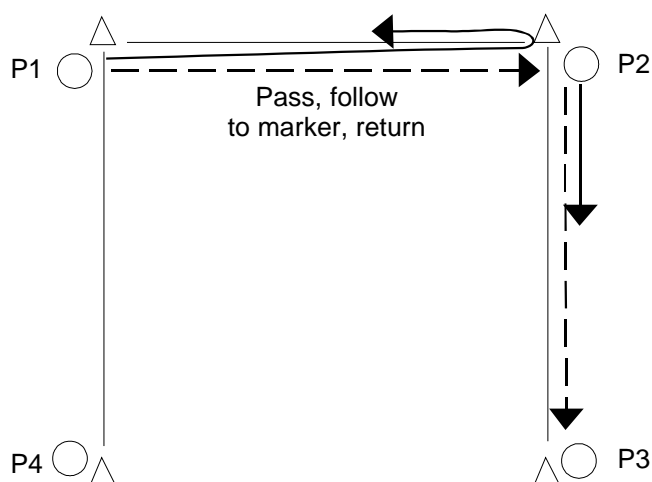

### Setting

4 players, Grid 5m X 5m

- 1 player starts on each corner
- P1 passes to P2
- P1 then follows the ball, touches the corner marker and returns to his original position to receive the next pass
- Each player takes his turn in passing and following, making sure to return to original position before receiving the pass
- Change direction of passing to use both left and right sides

### Points

Change size of grid, 2 metre grid will speed up the drill, a 10 metre grid will make the players work hard.

Vary running styles, have players run sideways so they are always facing the centre of grid or have them returning to original marker running backwards.



## DRILLS BOOK 2

VISIT THE  
WEBSITE TODAY!!

# Passing Circle

## (Cut One, Pass One)

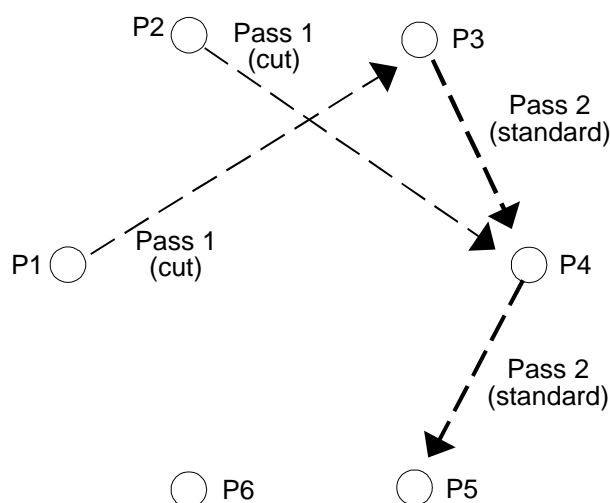

### Setting

6 players, 15m circle

- Equally space 6 players around a circle
- The drill starts with P1 and P2 each having a football, on coaches command they each make a cut pass to their left
- The receiving players then make a standard pass to the players on their left
- The new receivers then throw a cut pass to their left and the drill continues
- P1 and P4 will have to remain very alert as they will be passing cut and standard passes
- Restart the drill with P2 and P3 originally in possession

### Progression

Add an extra player so all players will have to remain alert as any player may end up with 2 balls being passed to him.  
Start the drill with initial passes being in the opposite direction.



VISIT THE WEBSITE TODAY!!

## DRILLS BOOK 2

# Quick Hands

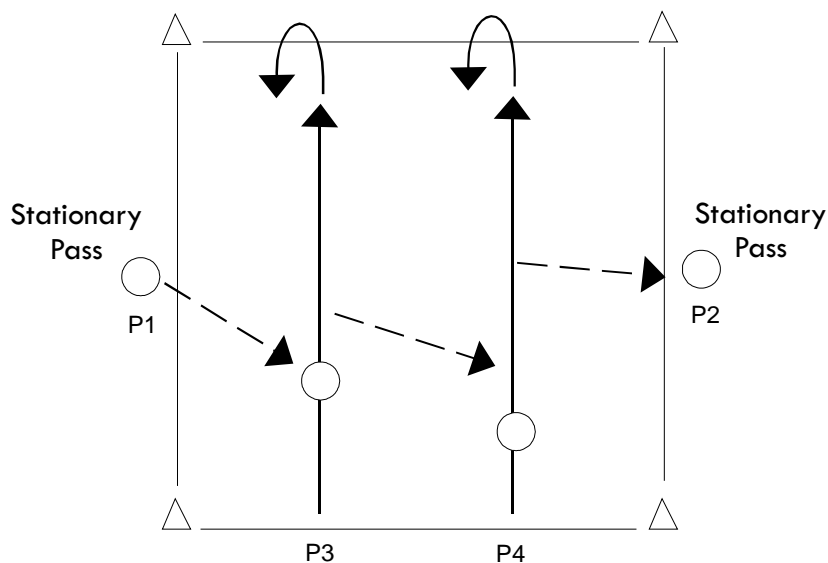

### Setting

4 players, Grid 10m X 10m

- P1 & P2 make stationary passes to P3 & P4
- P3 & P4 run back and forth across the grid making and receiving quick passes

RUGBY LEAGUE COACHING MANUALS *Online*  
**www.rlcm.com.au**

www.rlcm.com.au



## DRILLS BOOK 2

VISIT THE  
WEBSITE TODAY!!

# Traffic Pass (1)

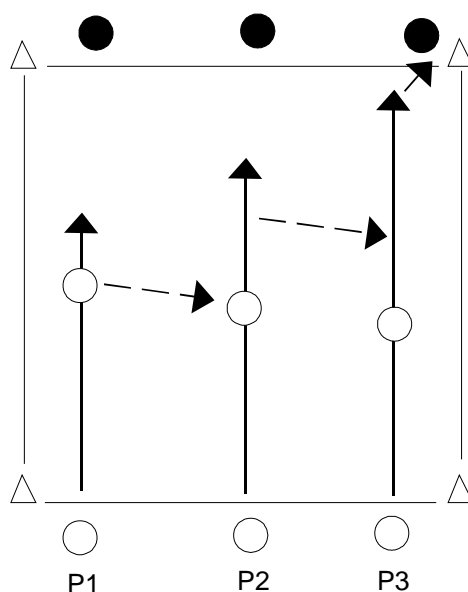

### Setting

Minimum 9 players, Grid 10m X 10m

- P1 passes to P2 who then passes to P3
- Drill progresses with the introduction of a second group running in the opposite direction creating player traffic
- Once players are proficient, increase the length of the grid and players running speed
- Have the group about to receive the ball run out from the line and receive the ball
- Players should rotate positions after each run through

www.rlcm.com.au



VISIT THE  
WEBSITE TODAY!!

## DRILLS BOOK 2

# Traffic Pass (2)

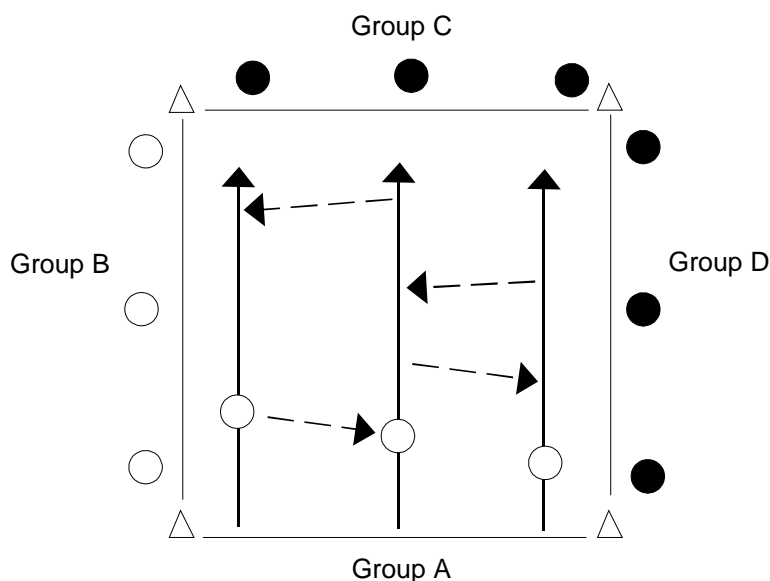

### Setting

4 Groups, 3-4 players per team, Grid 15m X 15m

- This drill is broken into 3 stages
- STAGE 1: Groups run forward and back across grid making as many passes as they can. Introduce competition by counting the number of passes made in a 30 second time limit
- STAGE 2: A second group is introduced (Group B) with players performing the same drill, however they run at right angles to Group A.
- STAGE 3: Introduce 2 more groups so there is a group running from each side of the grid, players perform the same drill as described above. Continue to add competition element of drill and nominate one player from each group to count passes.
- Have players rotate positions



VISIT THE WEBSITE TODAY!!

## DRILLS BOOK 2

# Traffic Pass (3) with Rotation

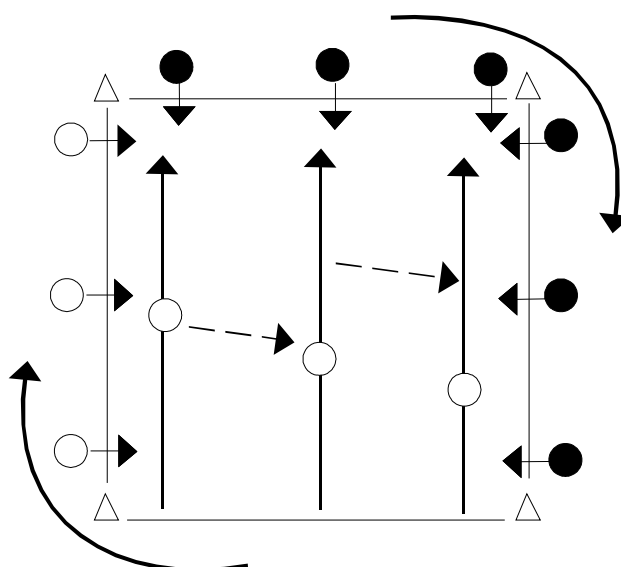

### Setting

4 Groups, 3-4 players per team, Grid 15m X 15m

- This drill continues from 'Traffic Pass (2)'
- Groups evenly space themselves along the sides of the grid
- The player on the right hand side starts with the football
- On coaches command players run through to the other side of grid passing the ball down the line
- The end player then places the ball on the ground and all players move to their right and line out along the next side of the grid
- The player that placed the ball then picks up the ball that has been placed by the group before and passes the ball out and the group continues through the drill

### Points

Drill should run continuously, player picking up the ball should do so on the run.

Communication within each group should be emphasised.



## DRILLS BOOK 2

VISIT THE  
WEBSITE TODAY!!

## Pass & Support

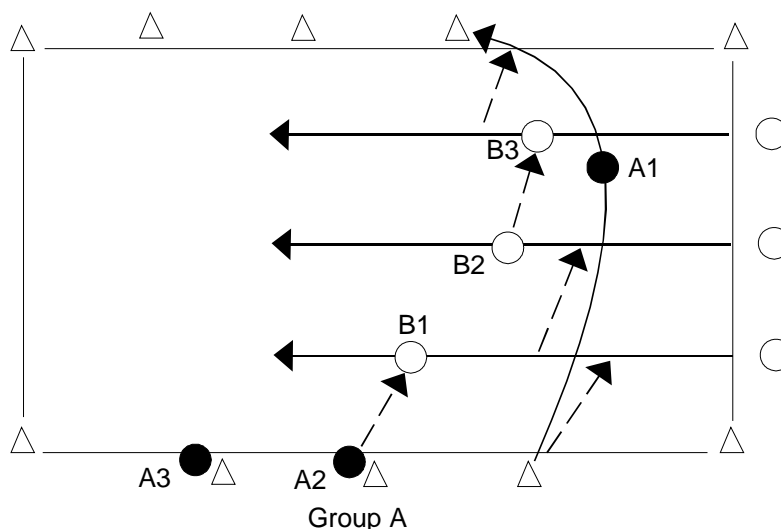

### Setting

9 players minimum, 30m x 15m channel

- Divide players into Groups of 3
- Position markers on the side of the grid, note that they should not be directly opposite each other
- Group A is positioned along the side of the channel and each player is given a football
- The drill commences with Group B running down the grid with player B1 receiving a pass from A1, the ball is then passed down the line
- Player A1 backs up and receives a pass from B3 before adopting a position on the first marker on the opposite side of the channel
- The drill continues with A2 passing to B1 etc
- When Group B reaches the end of the channel, they turn and then run back down the grid receiving passes from Group A players who are now positioned on the opposite side of the grid

www.rlcm.com.au



VISIT THE  
WEBSITE TODAY!!

## DRILLS BOOK 2

# Keep Away Grid (1)

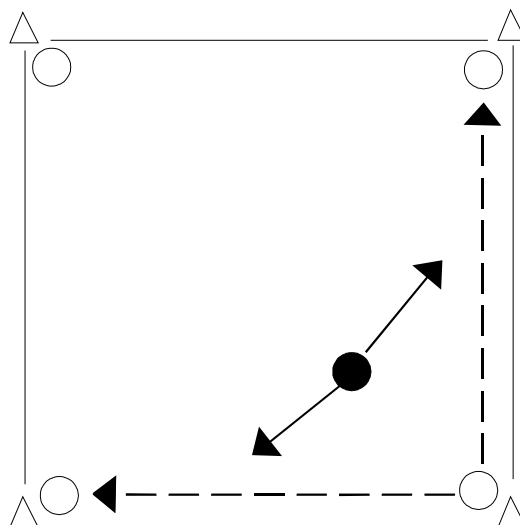

### Setting

5 players, Grid 5m X 5m

- One player is positioned on each corner of the grid and another in the middle of the grid
- Players on the corners pass the football amongst themselves attempting to keep the ball away from the player in the middle
- The player in the middle must attempt to intercept or knock down the pass
- Progress to having two players in the middle of the grid

### Points

Add a competition aspect into the drill by counting the amount of intercepts or knock-downs



## DRILLS BOOK 2

VISIT THE  
WEBSITE TODAY!!

# Elimination Tag

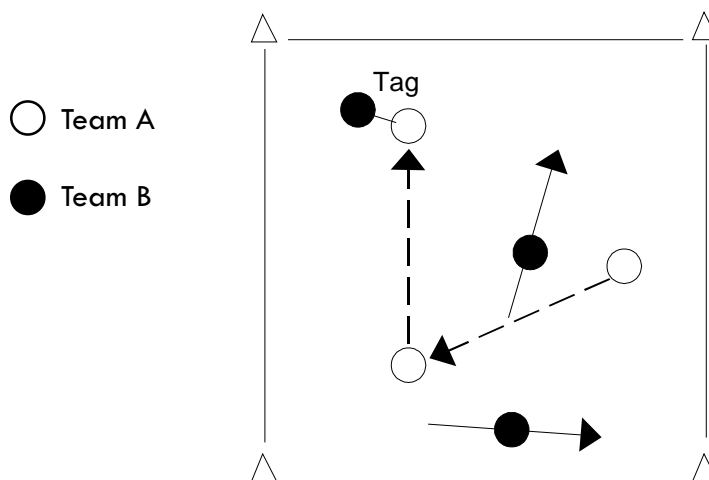

### Setting

2 teams, 3 players per team, Grid 10m X 10m

- Team A players pass the ball amongst team mates and attempt to tag members of the other team when holding the ball in two hands
- The player with ball in hand can not run with it
- Once player has been tagged he is eliminated from the game
- One player may re-enter the game each time a mistake is made by the team passing the ball

### Points

Communication and off the ball positioning are necessary to make the tags

www.rlcm.com.au



VISIT THE  
WEBSITE TODAY!!

## DRILLS BOOK 2

# Football Basketball

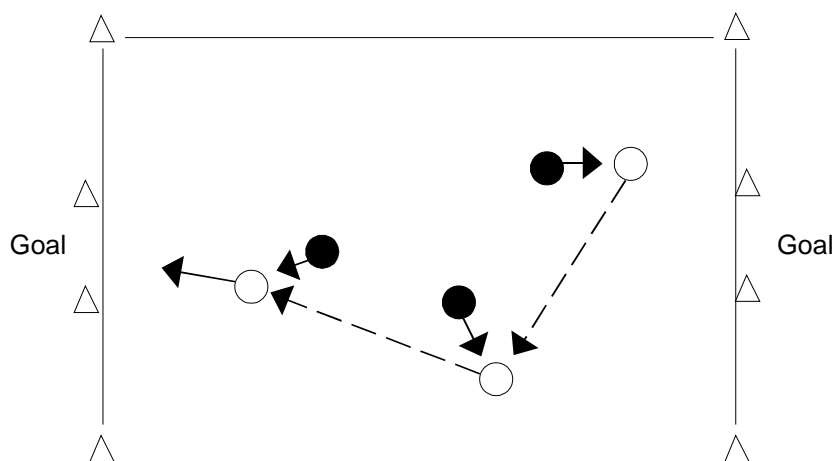

○ Team A

● Team B

### Setting

2 teams, 4-5 players per team, Grid 20m X 10m

- Divide players into 2 equal teams
- Team A starts with the ball
- Players can pass the ball and move in any direction in an attempt to score a try by running through the markers at each end
- Attacking gets 2/3/4 possessions in their attempt to score
- If the ball is dropped possession changes to the other side
- Having an additional player who always plays on the side of the team in possession allows for more scoring opportunities



VISIT THE  
WEBSITE TODAY!!

## DRILLS BOOK 2

# Line Passing

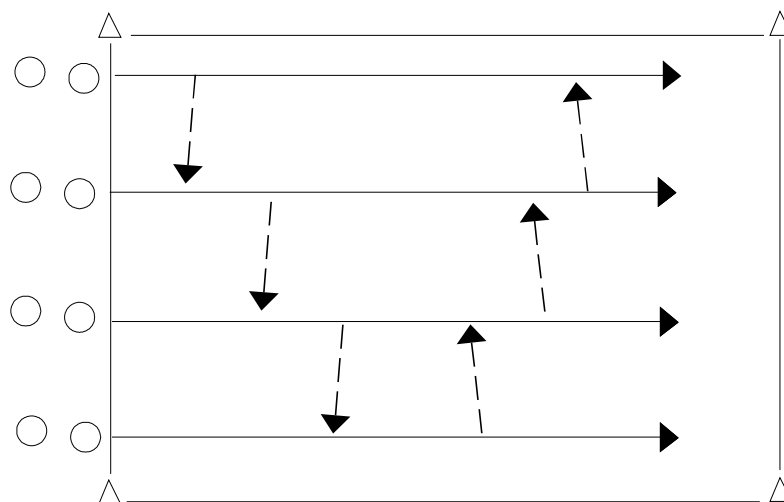

### Setting

3 Groups - 4 player per group, Channel 20m X 15m

- This drill has a progression of 4 stages
- STAGE 1: In Groups of 4 players run to the end of the channel passing back and forth. When the first group has reached the end, the next group heads off. Once all teams have gone through, repeat the exercise with players returning back down the channel
- STAGE 2: As in stage 1 but players immediately return back down the channel, passing the ball through the player traffic. Players should rotate positioning in the line with each run
- STAGE 3: Teams are positioned at each end of the channel, with one football repeat drill in relay fashion running at 3/4 speed
- STAGE 4: As in stage 3 but players run at full pace, passing the ball down the line only once and popping the ball to the next group at the end



VISIT THE WEBSITE TODAY!!

## DRILLS BOOK 2

# Pairs Passing

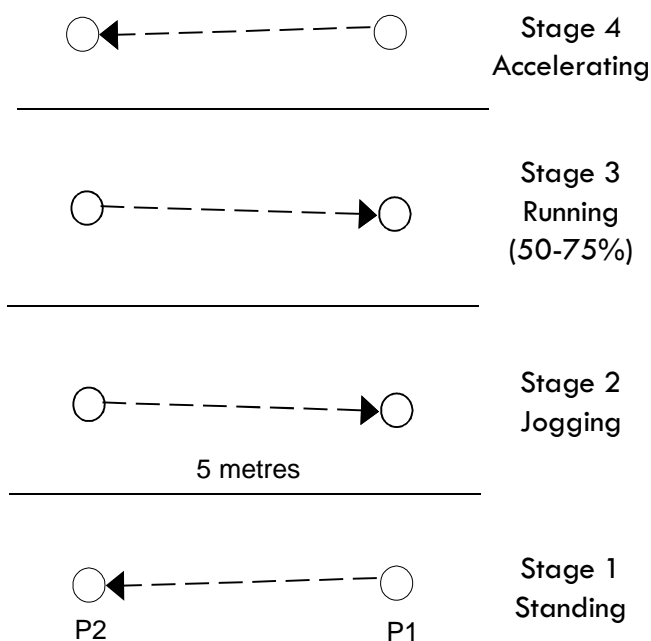

### Setting

2 Players per group, Channel 5m X 15m

- This drill has a progression of 4 stages
- STAGE 1: P1 & P2 stand no more than 5 metres apart, players pass ball between themselves taking a step with their outside foot and then passing
- STAGE 2: Same as mentioned above however this time players pass while jogging back and forth along the channel
- STAGE 3: As mentioned above but players increase pace to 1/2 to 3/4 speed
- STAGE 4: From standing start players accelerate over the 15 metre distance making one pass each

### Points

Emphasis for this drill is on good passing technique



VISIT THE  
WEBSITE TODAY!!

## DRILLS BOOK 2

# *Opposed Passing* **DRILLS**

The aim of fully opposed passing drills is to develop

- Reaction skills of support players
- Reaction skills of defenders
- Tackling skills
- Evasion skills
- Handling skills
- Communication skills

RLCM would like to thank Dave Ellis, Digi League and John Dixon, Brisbane Broncos for their assistance in compiling these drills.

Visit the **RLCM** website to order **Drills Handbooks**  
[www.rlcm.com.au](http://www.rlcm.com.au)

### **RLCM DRILLS** **Collection No.2**

Electronic Version \$22 AUD

- o Developing Speed and Agility for Mini and Mod
- o Touch / Tag Games for Rugby League
- o Play the Ball Drills o Tackling Drills
- o Passing Drills

[www.rlcm.com.au](http://www.rlcm.com.au)

1. Defence Grid
2. 2 on 1 in Channels
3. 2 on 1 Continuous
4. 3 on 2 Zone Defence
5. 3 on 2 Attack Support
6. 3 on 2 Up & Turn
7. 3 on 2 Roll Out
8. 3 on 2 Trailer
9. 3 on 1 on 1
10. 3 on 2 Reaction
11. 6 on 4 (2 Zones)
12. 6 on 4 (3 Zones)
13. Attack / Defence Reaction Drill
14. 3 on 3

[www.rlcm.com.au](http://www.rlcm.com.au)



**VISIT THE  
WEBSITE TODAY!!**

## DRILLS BOOK 2



## DRILLS BOOK 2

VISIT THE  
WEBSITE TODAY!!

## *Defence Grid 1*

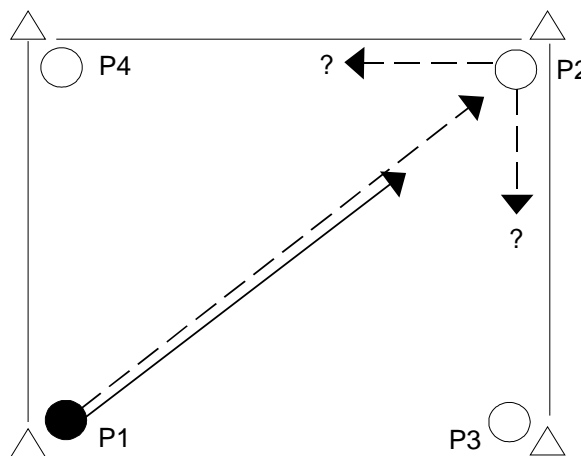

### Setting

4 Players, Grid 5m X 5m

- Drill begins with 4 players each positioned on a corner marker
- P1 starts the drill by passing across the grid to P2 (this is the only time the ball is passed across the grid)
- P1 then follows the ball to apply pressure on P2 who must quickly pass the ball on to either P3 or P4
- Should the ball be passed to P3 then P4 as the opposite player runs across to apply the pressure
- It is the player opposite the receiving player that applies the pressure
- In the meantime P1 must realign to be in a position to receive a pass from P3
- The drill should continue at full intensity for a duration nominated by the coach

**www.rlcm.com.au**



VISIT THE  
WEBSITE TODAY!!

## DRILLS BOOK 2

### *2 on 1 in Channels*

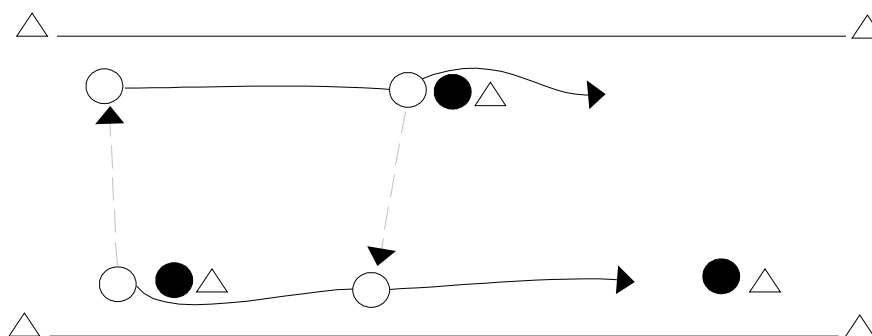

#### Setting

Grid 20m X 10m

- A minimum of 3 defenders position themselves in a staggered formation approximately 5 metres apart facing the remaining players
- The remaining players are paired up, each pair with a ball, they proceed down the grid attempting 2 on 1 on each defender

#### Stage 1

Defenders may only move sideways and not advance on attackers

#### Stage 2

Defenders can move across onto and tag the receiver if the ball has been passed too early or the defender has not been drawn properly

#### Stage 3

Defenders can advance on attackers applying maximum pressure. Once a pair has beaten the first defender the next pair may start. When all pairs have gone through, defenders face the other direction and the attackers go again

#### Variation

- Progress to have defenders standing directly behind each other



VISIT THE  
WEBSITE TODAY!!

## DRILLS BOOK 2

### *2 on 1 Continuous (1)*

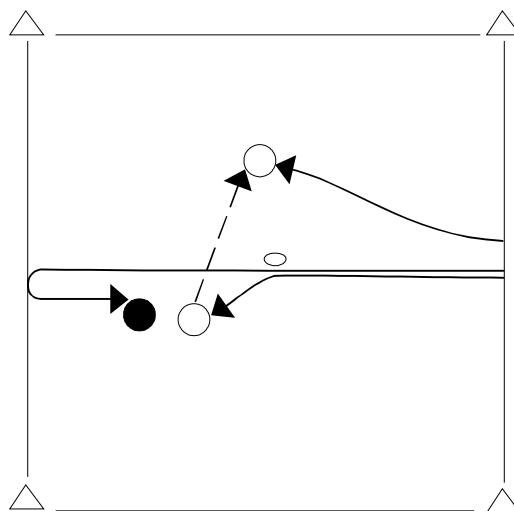

#### **Setting**

3 players, Grid 10m X 10m

- All 3 players start the drill from the start line
- One player is nominated as the defender, the other two as attackers, the defender is given the football
- The drill starts with the defender running across the grid, placing the ball in the centre of the grid and then proceeding to the other end where he turns to defend against the attackers
- The two attackers may not leave the line before the ball has been placed on the ground
- After regathering the ball the attackers must attempt to beat the defender with a draw and pass or dummy pass and then proceed through to to the other end of the grid
- The ball is then given back to the defender and the drill continues
- Attackers must take turns as the player picking up the football, work at least 6 plays before rotating the defender

#### **Progression**

- Can be 3 on 2



VISIT THE  
WEBSITE TODAY!!

## DRILLS BOOK 2

### *3 V 2 Zone Defence*

---

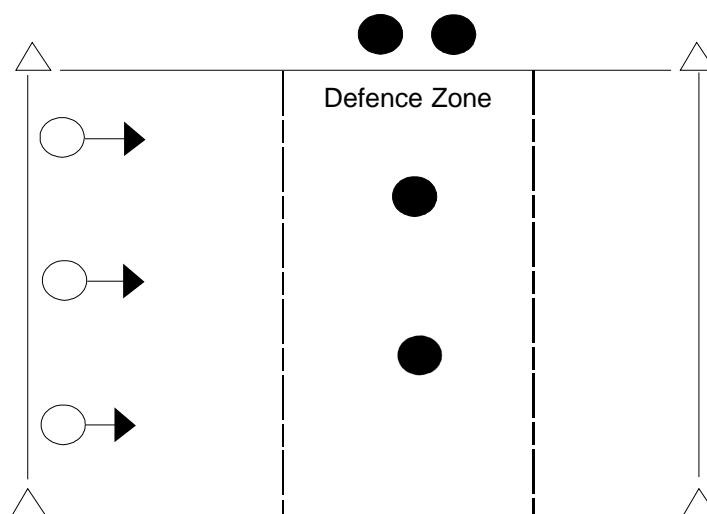

#### **Setting**

Minimum 5 Players per group, Grid 25m X 15m

- This is a competitive drill which should run for a duration of 5 minutes
- 3 Attackers set out down the grid with the aim of beating the 2 Defenders and scoring at the opposite end
- Defenders may only work in the specified area and must attempt to wrap the ball or force an error
- After each play, the 2 defenders are changed in readiness for the next attack, the attackers must immediately reform at the opposite end of the channel once they have scored or a breakdown has occurred and then attack again
- Attackers and Defenders should be rotated after 5 minutes

**www.rlcm.com.au**



VISIT THE WEBSITE TODAY!!

## DRILLS BOOK 2

### *3 on 2 Attack Support*

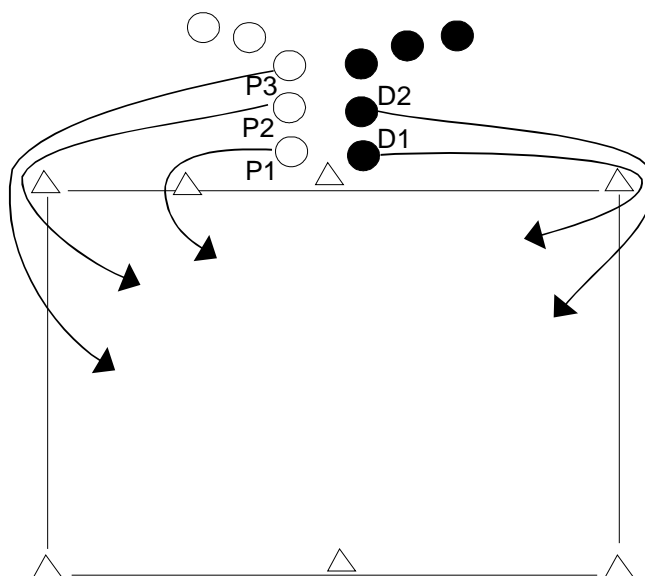

#### **Setting**

2 Teams, Grid 20m X 15m

- Players are divided into 2 teams and positioned as shown in diagram. The attacking team must attempt to score at the far end of the grid
- On coaches command 3 attackers (P1, P2, P3) and 2 defenders(D1, D2) run around the markers as shown
- P2 and P3 run around marker 2 while P1 with ball in hand enters the grid by running around marker 1
- P1 will enter the grid first to start the attack forcing D1 and D2 to react quickly and creates urgency for P2 and P3 to move at pace into support positions



VISIT THE  
WEBSITE TODAY!!

## DRILLS BOOK 2

### *3 on 2 Up & Turn*

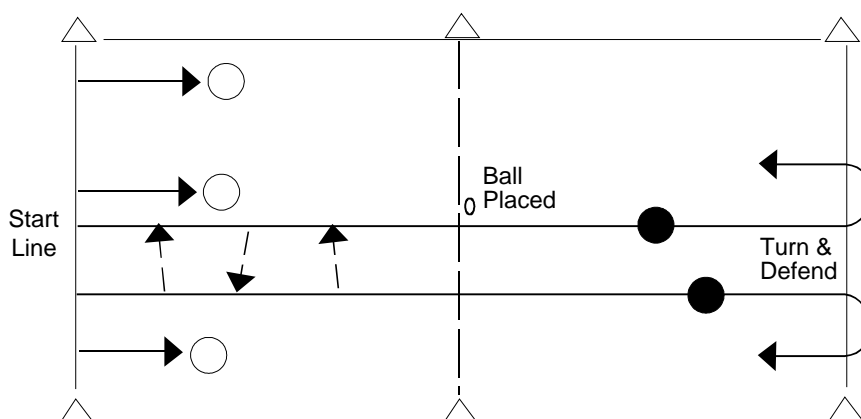

#### **Setting**

5 players, Grid 30m X 15m

- All 5 players commence the drill from the start line
- On the coaches command the 2 players run down the grid passing the ball back and forth
- Upon reaching the centre line of the channel, the ball is placed on the ground, the 2 players then sprint to the end of the grid where they turn to become defenders
- The remaining 3 players proceed down the grid once the ball has been placed on the ground, the middle player picks up the football and they proceed to attack in a 3 on 2 situation

#### **Variation**

- Defenders place the ball on the centre line but at the side of the grid creating a 3 on 2 ball at the end situation
- Defenders place the ball anywhere on the centre line



VISIT THE  
WEBSITE TODAY!!

## DRILLS BOOK 2

### *3 on 2 Roll Out*

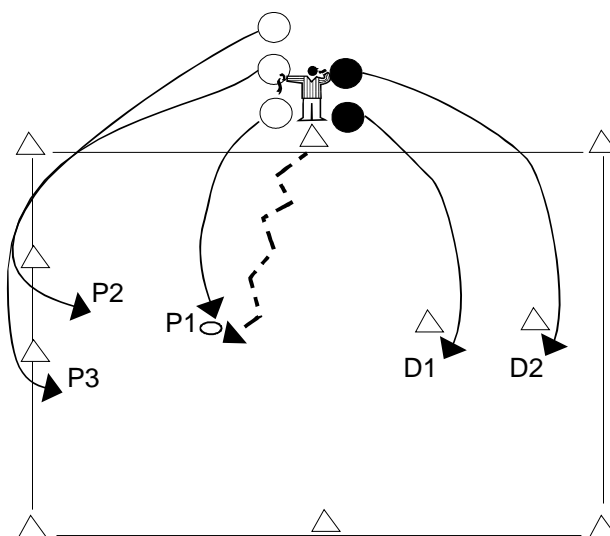

#### Setting

5 Players, Grid 30m X 20m

- The drill provides a variation to 3 on 2 Attack and Support
- Players are divided into 2 teams, the attacking team must attempt to score at the far end of the grid
- One marker is placed in the centre of the far end of the attackers side of the grid and two markers on the defenders side
- The coach holding the ball should be in a central position on the side of the grid
- The drill commences with the coach rolling the ball to the centre of the grid, immediately, the 3 attackers (P1, P2, P3) and 2 defenders (D1, D2) run around their respective markers.
- P1 will go directly to the ball to start the attack, P2 and P3 will become support players
- D1 and D2 will separate and run around their designated marker before confronting the attackers
- Drill can be played as 'touch', '2 handed grab', 'wrap up' or 'tackle'

www.rlcm.com.au



VISIT THE WEBSITE TODAY!!

## DRILLS BOOK 2

### *3 on 2 Trailer*

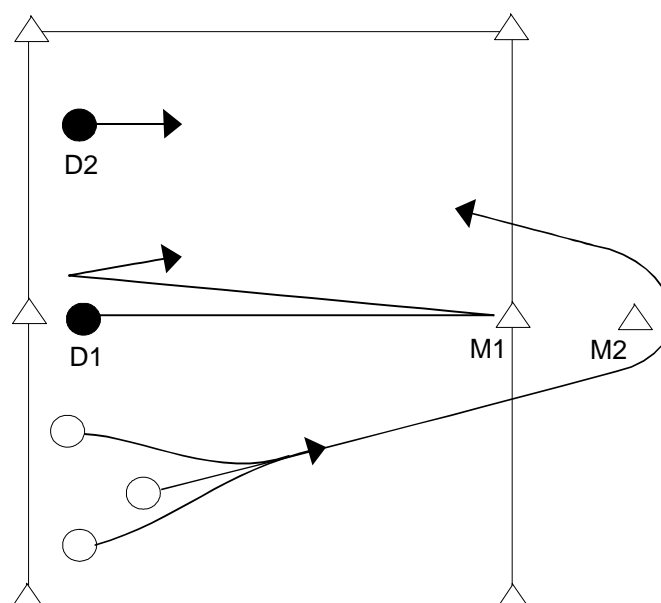

#### **Setting**

5 Players, Grid 20m X 30m

- Attackers and Defenders start beside each other on the start line
- To start the drill attackers run with the ball across the grid and around a marker (M2) that has been placed outside the grid
- After rounding M2 players turn and form an attacking alignment
- From the start one defender D1 runs with the attackers to the opposite end of the grid (M1), touches the ground and then runs backwards linking with D2 to defend their line
- To introduce the drill to beginners move M1 closer to D1



VISIT THE  
WEBSITE TODAY!!

## DRILLS BOOK 2

### *3 on 1 on 1*

---

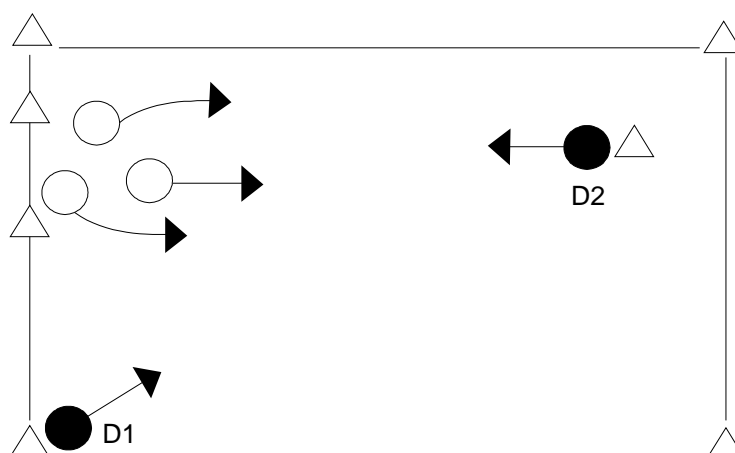

#### **Setting**

5 Players, Grid 40m X 20m

- Drill commences with 3 attacking players running between 2 markers placed approximately 1.5 metres apart at one end of the grid
- 2 defenders start from designated areas and must attempt to prevent the attacking players from scoring
- D1 acts as a cover defender and commences his run from the corner of the grid as the attacking players pass between the starting markers
- D2 is a front-on defender and starts from the far end of the grid
- Defenders must communicate to prevent the try from being scored and attackers must attempt to manipulate the defence in order to put a player into space



VISIT THE WEBSITE TODAY!!

## DRILLS BOOK 2

### 3 on 2 Reaction

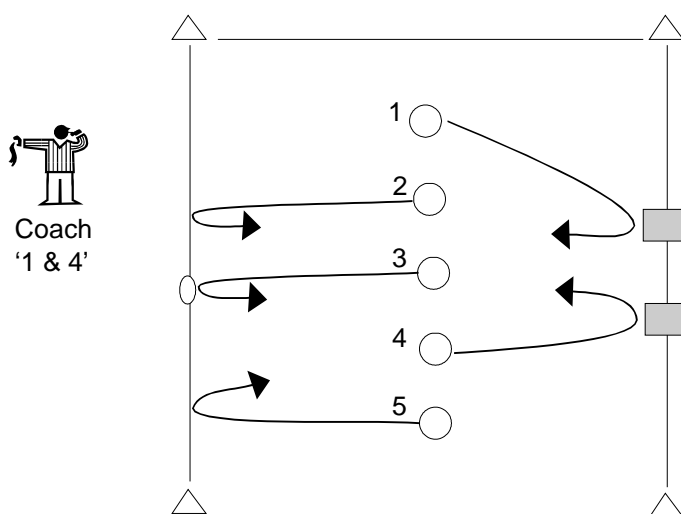

#### Setting

5 players, Grid 10m X 10m

- The 10m grid is set up with 2 hit pads at one end and a football at the opposite end, markers should also be placed on the side of the grid marking the half way.
- All 5 players line up on the half way facing the hit pads, each player is given a number from 1 to 5.
- The coach calls out 2 numbers, this is the command for those 2 players to sprint and pick up the hit pads and the remaining 3 players to return to the other end and regather the football
- The 3 players with the ball are now attackers and must attempt to avoid the hit pads and score at the opposite end.

#### Variation

Players start lying on the ground

Position hit pads in different area within the grid

Increase the size of the grid and the number of players



VISIT THE  
WEBSITE TODAY!!

## DRILLS BOOK 2

### *6 on 4 (2 Zones)*

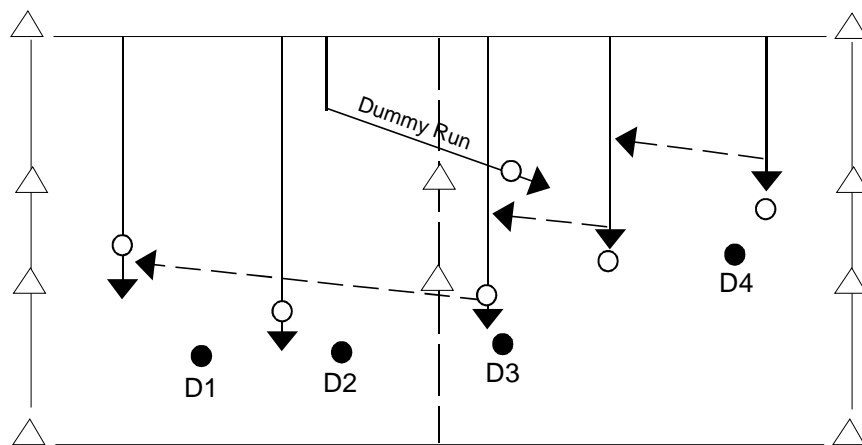

#### Setting

10 Players, Grid 30m X 20m

- 6 attackers line on the long side of the grid with 1 football
- The 4 defenders holding hit pads position themselves approximately half way down the grid
- The rules for the defenders is that the middle two (D2, D3) may roam anywhere they wish however the outside two (D1, D4) are restricted to their half of the grid and may not cross the centre line
- Any player in the attacking team may start the drill which is a 6 on 4 competition
- The remaining 6 players are the attackers and must attempt to score as many tries as possible in 3 minutes
- The attacking team must restart play from the start line after each try or breakdown
- A breakdown occurs when the ball is knocked on, when the ball has been passed forward or when a defender performs a solid hit on the ball carrier
- Two handed grab may be used when hit pads are not available

www.rlcm.com.au



VISIT THE WEBSITE TODAY!!

## DRILLS BOOK 2

# 6 on 4 (3 Zones)

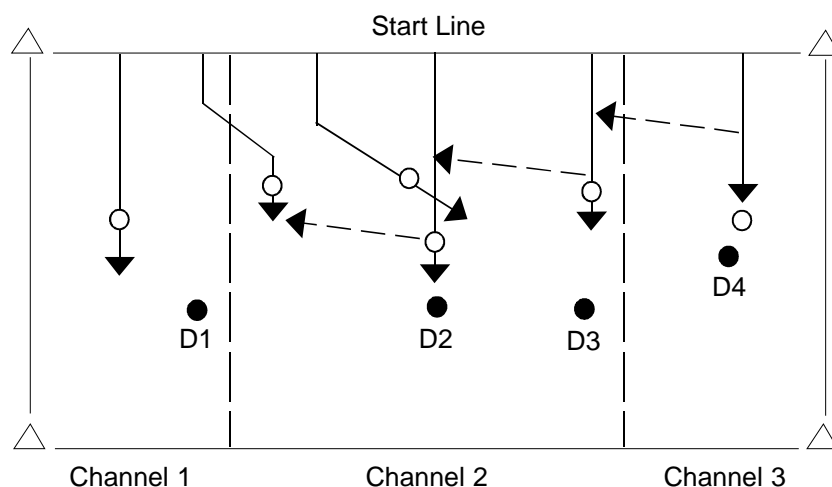

### Setting

2 Teams, 10 players, Grid 40m X 30m

- Grid is divided into 3 channels
- 4 players with hits pads must attempt to defend the try line however they must remain within their allocated channel
- D1's channel is the 10m on the left, D2 and D3 is the 20m in the centre and D4 is the 10m on the right of the grid, defenders may roam anywhere within their channel

RUGBY  
LEAGUE  
COACHING  
MANUALS

Since 1993

*"I believe all clubs and coaches at all levels should have a copy of this magazine as a coaching resource"*

**WAYNE BENNETT**

**Freecall 1800 18 14 14**



## DRILLS BOOK 2

VISIT THE  
WEBSITE TODAY!!

## *Attack/Defence Reaction Drill*

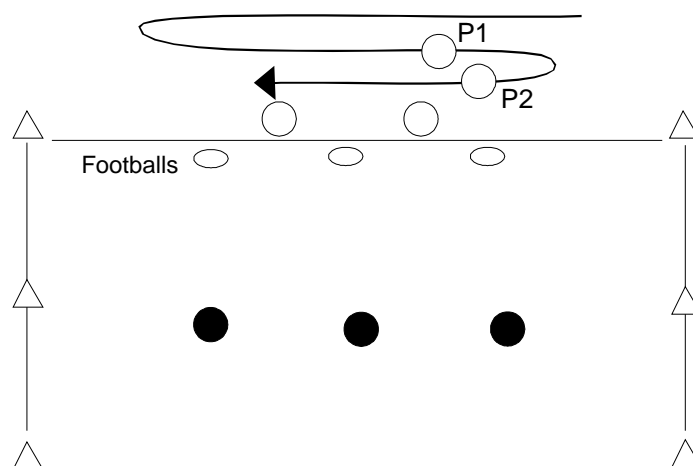
**Setting**

2 Teams, 7 players, Grid 20m X 40m

- Players are divided into 2 teams, one team is the attackers the other becomes defenders
- The defending team is positioned along the middle line of the grid
- 2 attackers position themselves close to the centre of the 40m side of the grid
- 3 balls are positioned between the attackers as shown in the diagram
- On coaches command the 2 remaining attackers (P1 and P2) move back and forth behind the stationary attackers.
- At any time P1 or P2 may pick up a ball and start the attack
- On the pick up both teams come into play and the attackers must attempt to score on the other side of the grid
- Teams swap roles after each play

**Variation**

4 x 4.



VISIT THE WEBSITE TODAY!!

## DRILLS BOOK 2

### 3 on 3

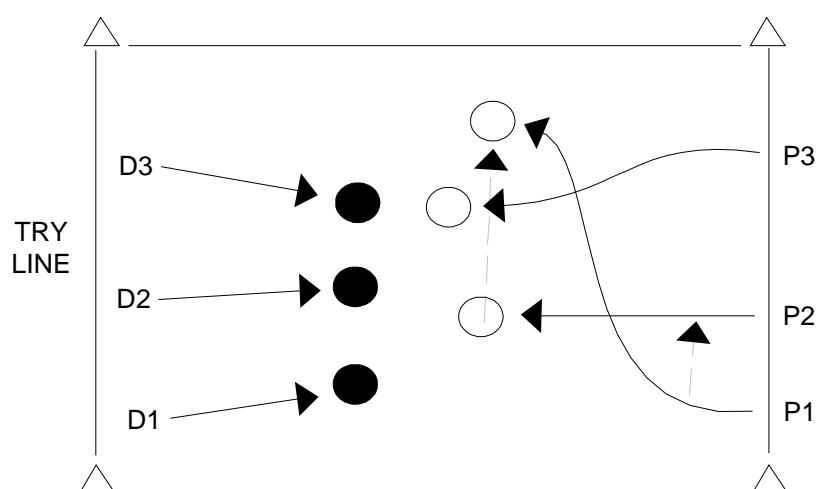

Example 'P1' passes and then runs a loop to the outside

#### Setting

6 Players, Grid 20m X 15m

- 3 Attackers and 3 Defenders start at opposite ends of the grid
- The aim of the drill is for the attackers to beat the defenders and score a try, players may make own decision as to what play to perform and skills to be used

- Stage 1** Defenders to stop attack by a successful two handed grab
- Stage 2** Defenders stop attack by performing a successful full contact tackle below the waist
- Stage 3** Play stops when the attacking team scores or commits an error, full contact tackles are made with no tackle limit

This drill is best practiced on soft surfaces e.g. beach and in small areas



VISIT THE  
WEBSITE TODAY!!

## DRILLS BOOK 2

# rlcm.com.au

The publishers wish to thank the Australian Rugby League and contributors for their assistance in compiling this publication.

**Queensland**  
Suite 1F, Trust House  
3070 Gold Coast Hwy  
Surfers Paradise  
QLD AUST. 4217

PO Box 259,  
Surfers Paradise  
QLD AUST. 4217  
Ph: (07) 5538 9377  
Fax: (07) 5538 9388

**New South Wales**  
Suite 111  
353 King Street  
Newtown  
NSW AUST. 2042

Locked Bag 18/111  
Newtown  
NSW AUST. 2042  
Ph: 1800 18 14 14  
Fax: 1800 18 14 15

### UNITED KINGDOM

The Conifers, 1 New Lane,  
Skelmanthorpe,  
Huddersfield  
West Yorkshire  
UK HD8 9EH  
Email: england@rlcm.com.au

### NEW ZEALAND

132 Victoria Road,  
St Kilda, Dunedin,  
New Zealand  
Fax (03) 456 3498,  
Email: rlcm@ihug.co.nz

**Publisher**  
Gary Roberts  
rlcm@rlcm.com.au

**Research**  
Keith Hookway  
keith@rlcm.com.au

**Editor**  
Terry Prindable  
editorial@rlcm.com.au

**Production**  
Reagan Roberts  
reaganr@ozemail.com.au

**Contributors**  
Digi League  
SA Rugby League  
John Dixon

Endorsed By



### DISCLAIMER

The information in this publication is given in good faith and has been derived from sources believed to be reliable and accurate. However, neither Shamrock Books, nor any person involved in the preparation of this publication accept any form of liability whatsoever for its contents including advertisements, editorials, opinions, advice or information or for any consequence for its use.

**No part of this publication may be reproduced, stored in any retrieval system, or transmitted in any form or by any means electronic, mechanical, photocopying, recording or ink-jet printing without prior written permission of the publishers.**

Published by Senior Scene Pty Ltd  
T/A Shamrock School Books  
ABN 82 050 409 268

Rugby League Coaching Manuals  
ISSN 1446-3628

www.rlcm.com.au